

Please read **BOTH** these Installation Instructions and the General Towing Instructions before attempting to install or operate this equipment.

- Blue Ox® towing products and accessories are intended to be installed by Blue Ox® Dealers who are familiar with our products and have the equipment and knowledge to do “fit work”. When necessary, Blue Ox® Dealers can be found at [www.blueox.us](http://www.blueox.us) or by contacting our 24/7 Customer Care Department at (888) 425-5382.
- Many Blue Ox® Baseplates are designed to use existing holes and hardware to mount the baseplate to the towed vehicle. Even though bolts are there, do not assume they are adequate for baseplate mounting. Always use hardware supplied in the hardware kit or existing hardware specified in the Baseplate Installation Instructions.

Attachment Tab Height: 11”  
Attachment Tab Width: 24”

**Bolt Torque Specifications**

Torque in Foot-Pounds per Metric Bolts

Bolt Size	Grade 8.8	Grade 10.9
6MM	6	8
8MM	16	22
10MM	31	40
12MM	54	70
14MM	89	117

Confirm the towability and pre-towing procedures for your vehicle with the owner’s manual or contact the vehicle’s manufacturer for specific towing procedures. You can also contact REMCO for additional information at 1(800)228-2481.

**Bolt Torque Specifications**

Torque in Foot-Pounds per Inch Bolts

Bolt Size	Grade 5	Grade 8
1/4”	10	14
5/16”	19	29
3/8”	33	47
7/16”	54	78
1/2”	78	119
5/8”	154	230



**! WARNING**

Failure to read and follow these instructions could result in separation of the towed vehicle from the tow bar, causing property damage, loss of towed vehicle, personal injury or death.

BX1669  
2006-07 Cadillac STS  
Installation Instructions

## Parts List

Ref. No.	Qty.	Part #	Description
1	1	61-6264	Weldment, Baseplate, BX1669
2	8	61-3799	1/2-13 Nut Plate with 10" Wire
3	8	201-0051	1/2-13 x 1 1/2" Hex Bolt Grd. 5, ZP
4	8	203-0012	1/2" Lock Washer, ZP
5	2	201-0979	#12-14 x 1" Self Drilling Screw, ZP
6	2	201-0192	10-32 x 1/2" Slot, Rd. Hd. Screw
7	2	203-0054	#10 Lock Washer
8	2	202-0047	#10-32 Hex Nut
9	2	101-5822	Adapter, 4 Way Connector
10	2	62-3468	Attachment, Assembly, SF/SB (R)
	2	226-0049	Baseplate Safety Cable, 36" CL IV (Not Shown)
	2	229-0512	Quicklink, 1/2, ZP (Not Shown)
	2	290-0437	Cap Plug, Black (Not Shown)

## Tools Required

Loctite® RED  
7mm Socket  
10mm Socket  
3/4" Socket  
Diagonal Cutters  
17/32" Drill Bit  
Large Vise Grips

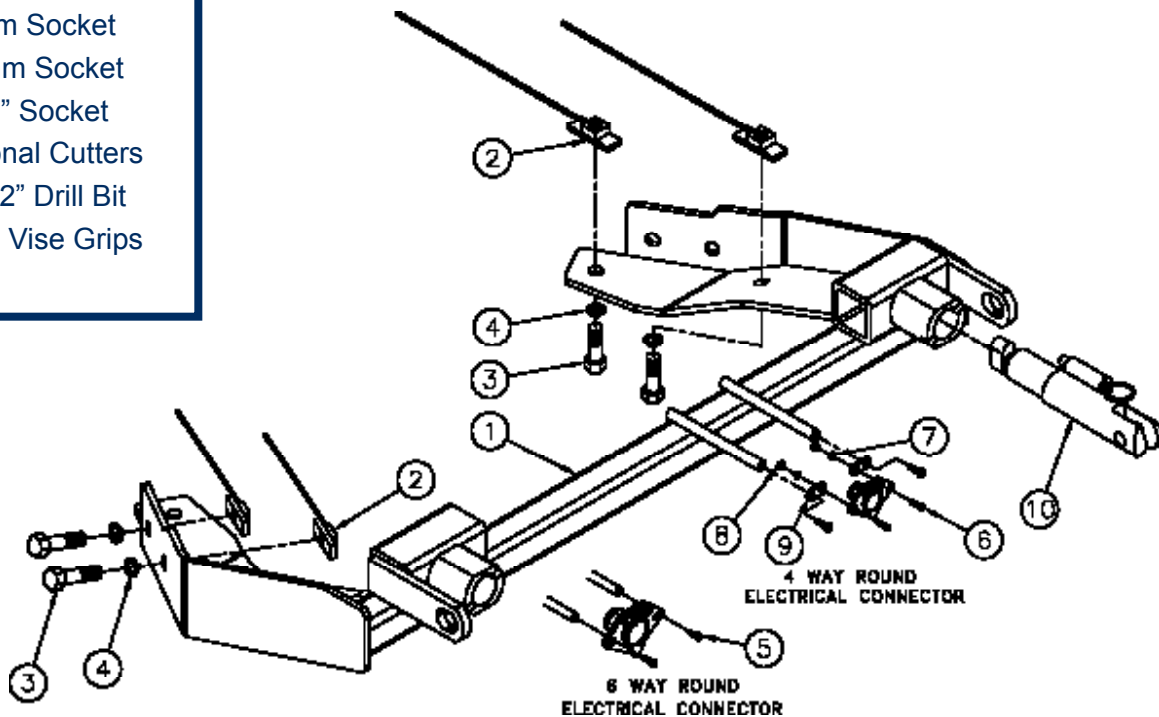

### Important:

Use only genuine factory replacement parts on your baseplate. Do **NOT** substitute homemade or non-typical parts. If a bolt is lost or in need of replacement, for your safety and the preservation of your baseplate, be sure to use a replacement bolt of the same grade (In most cases it will be Grade 5, please reference the parts list above). Replacement parts may be ordered through your nearest Blue Ox® Dealer or Distributor.

BX1669  
2006-07 Cadillac STS  
Installation Instructions

**Attachment Tabs:**

Due to the design of the removable tabs, the RangeFinderII tow bar can not be used. Adapters, except the BX8833 and BX88151, can not be used with this baseplate.

**Installation Notes:** The engine compartment covers, fascia and belly pan are removed for installation. Drilling is required. The grille must be trimmed.

The dimensional variations between otherwise identical vehicles can be considerable. While the baseplate was designed for easy installation, it may be necessary to tailor the baseplate slightly to compensate for auto manufacturer's tolerances. These minor adjustments may include filing a hole slightly, bending electrical rods, and/ or bending end plates.

The BX8848 Diode Wiring Kit is recommended for this vehicle.

**Installation Instructions:**



1. Above the grille, remove two pushpins (see white arrows) from the outer edge of the black plastic engine compartment cover. Remove cover and set aside with pushpins to be reinstalled later. Remove one pushpin from the center engine compartment cover (see grey arrow). Do this to both sides of the vehicle. Set cover and pushpins aside to be reinstalled later.



2. On the upper corner of grille, remove one pushpin (see grey arrow). Remove two pushpins from the upper corner of fascia (see white arrows). Do this to both sides of the vehicle. Set pushpins aside to be reinstalled later.

BX1669  
2006-07 Cadillac STS  
Installation Instructions



3. Just forward of the front tire, inside the wheel well, remove two pushpins. Do this to both sides of the vehicle. Set pushpins aside to be reinstalled later.



4. Remove eight pushpins from the bottom of fascia (driver's side shown). Do this to both sides of the vehicle. Set pushpins aside to be reinstalled later.



5. Using the 7mm socket, remove two metric bolts from the lower outside edge of the fascia. Do this to both sides of the vehicle. Set bolts aside to be reinstalled later.

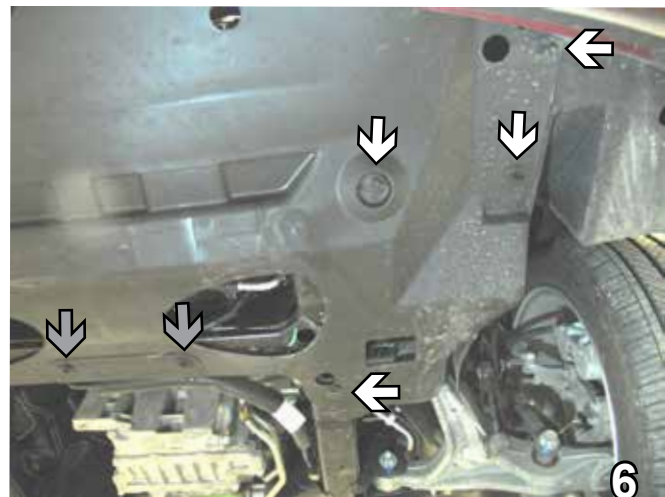

6. Remove four pushpins from the outer edge of the belly pan (see white arrows). Do this to both sides of the vehicle. Remove two pushpins from the center of the belly pan (see grey arrows). Remove belly pan. Set pushpins and belly pan aside to be reinstalled later.



BX1669  
2006-07 Cadillac STS  
Installation Instructions



7. Using the 10mm socket, remove one hex bolt (see white arrow) and loosen (do not remove) stud nut just forward of the front tire inside the fender well. Do this to both sides of the vehicle. Set bolts aside to be reinstalled later.



8. Just behind the grille, attached to the fascia, remove one Christmas tree pushpin from the air dam to loosen the air dam from the fascia (do not remove). Do this to both sides of the vehicle. Pull the fascia forward to remove. Set pushpins and fascia aside to be reinstalled later.



9. Align the baseplate against the lower frame extensions, so that the top of the cross tube is four inches from the bottom of the bumper. Clamp the baseplate in place with the large vise grips. **Baseplate is painted white for illustration only. Actual baseplate is black powder coat.**



10. Using the baseplate as a template, drill two holes into the bottom of the frame with the 17/32" drill bit. Do this to both sides of the vehicle.

BX1669  
2006-07 Cadillac STS  
Installation Instructions

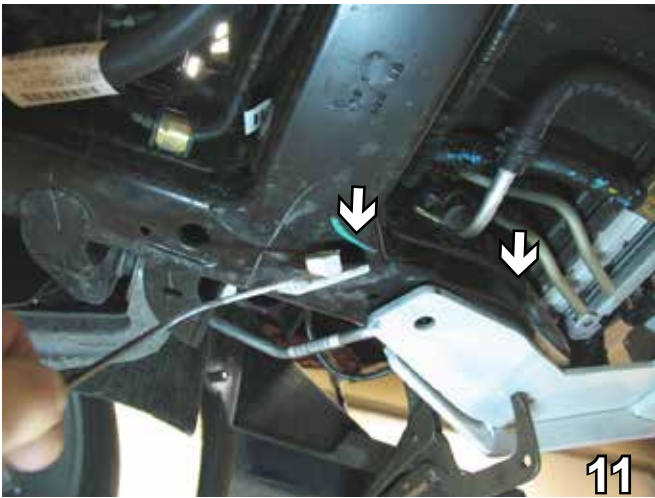

11. Insert 1/2-13 nut plate through one of the frame openings (see white arrows) and align to drilled holes. Insert the 1 1/2-13 x 1 1/2" hex bolts and 1/2" lock washers. Align with nut plates and tighten with the 3/4" socket. Trim nut plate wires. Do this to both sides of the vehicle.



12. Using the baseplate as a template, drill two holes into the side of the frame with the 17/32" drill bit. Insert 1/2-13 nut plate through one of the frame openings and align to drilled holes. Insert the 1 1/2-13 x 1 1/2" hex bolts and 1/2" lock washers. Align with nut plates and tighten with the 3/4" socket. Trim nut plate wires. Do this to both sides of the vehicle.

**BE SURE TO USE LOCTITE® RED ON ALL BOLTS BEFORE TIGHTENING. TIGHTEN ALL BOLTS ACCORDING TO THE TORQUE CHART ON THE FRONT PAGE OF THESE INSTRUCTIONS OR ON PAGE 3 OF THE BASEPLATE TOWING GENERAL INSTRUCTIONS.**

13. Reinstall belly pan and all pushpins. Insure air dams are tucked behind the baseplate as they are not reattached to fascia.

Be sure that **ALL** electrical connections are plugged in properly and functioning **BEFORE** installing the fascia.



14. Hold the fascia up to its original location. Mark and trim the grille with the diagonal cutters as necessary for the attachment tabs, convenience links and electrical rods to come through. Reinstall the engine compartment covers and fascia.

BX1669  
2006-07 Cadillac STS  
Installation Instructions

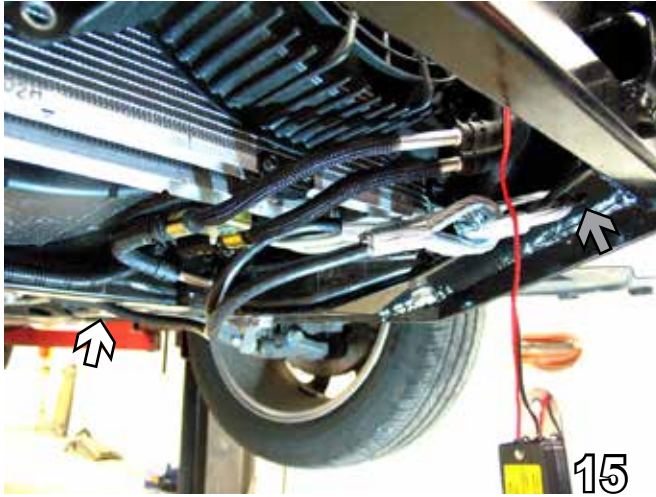

**DEALER or INSTALLER:**  
**Be certain the user receives the instruction sheets for their products.**

Install the tow bar and safety cables according to the instructions provided in their packages. When demonstrating this to the customer, be sure to include all the contents and packages.

Do **NOT** substitute other devices if the tow bar pins and clips are misplaced.

15. Attach the permanent baseplate safety cables to the provided convenience link on the baseplate (see grey arrow). The photo above shows the recommended installation of the permanent baseplate safety cables to frame of the vehicle (see white arrow). If the vehicle has additional options, not shown above, which interfere with mounting the permanent baseplate safety cables, secure the cable to a solid piece of the vehicle's frame as described in the instructions included with the permanent baseplate safety cables.



BX1669  
2006-07 Cadillac STS  
Installation Instructions

## Customer Service Commitment

Blue Ox® is focused on providing exemplary customer service, as observed in our mission statement and guiding principles. In accordance with this objective, Blue Ox® is proud to provide services such as repairs and general maintenance of Blue Ox® products at over 150 RV Rallies. Look for our Destination America or Blue Ox® Racing service crews at the next rally or race that you attend. If you were not present, you will find an informative, personalized note explaining any services that may have been performed to your Blue Ox® products.

Blue Ox® also offers educational seminars at rallies and through our Park and Resort teams. In addition, Blue Ox® customers visiting our factory may take advantage of the well-equipped Blue Ox® RV park at no charge to you, our valued and appreciated customer.



© 2006 Blue Ox  
One Mill Road, Industrial Park  
Pender, Nebraska 68047  
Phone: (402) 385-3051 • Fax: (402) 385-3360  
[www.blueox.us](http://www.blueox.us)



# General Information

1. Ensure that your product(s) are registered online at [www.blueox.com](http://www.blueox.com). It is crucial to register your product(s) so that you may be alerted of product offerings, updates, upgrades, maintenance and safety bulletins, and/or recalls.
2. **It is the owner's responsibility to inspect all towing equipment for cracked welds, missing or worn parts and loose bolts before each towing trip.** Be sure to use Loctite® Red on all bolts and tighten to the recommended specifications.
3. **It is the owner's responsibility to hook up all towing equipment per manufacturer's instructions/recommendations.**
4. Remove the attachment tabs when not in use (if applicable).

## Notice To Baseplate Installer

### 1. It is YOUR responsibility to watch for:

- Oil cooler and air conditioner lines
- Electrical wires and hoses
- Missing parts or attaching points on the frame

\*\* If the baseplate is improperly installed and is against a wire or hose, it could cause fluid leaks or electrical shorts some time after the actual baseplate installation.

## Permanent Baseplate Safety Cable Installation

Permanent baseplate safety cables are strongly recommended when towing a vehicle with a tow bar. The principle function of the permanent baseplate safety cables is to prevent the towed vehicle from breaking loose in the event the connection between the frame of the towed vehicle and the baseplate fails or becomes disconnected. The cables must be connected from the baseplate to the frame rail or cross member of the vehicle's frame. The illustrations below show the possible arrangements recommended by Blue Ox®. Each permanent baseplate safety cable must have an adequate weight rating for the towing system. The weight rating of the two (2) cables together will not qualify.

***Do not mount the permanent baseplate safety cables against wires, hoses or brake lines.***

These permanent baseplate safety cables should remain installed as long as the baseplate is installed on the vehicle. Permanent baseplate safety cables are to be used in conjunction with, and NOT a replacement for legally required safety cables attaching the towed vehicle to the towing vehicle.

### OPTION #1

Permanent Baseplate Safety Cables to Cross Member or Frame of Towed Vehicle.

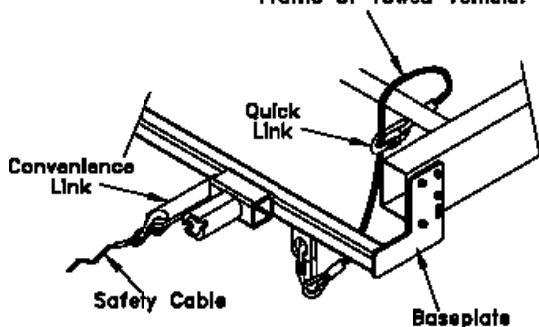

### OPTION #2

Permanent Baseplate Safety Cables to Cross Member or Frame of Towed Vehicle.

