



Strong As An Ox™

## BX1831 Installation Instructions 2004-08.5 Nissan Titan, 4 x 4

Serial No.

The belly pan, front grill and metal bumper are removed for baseplate installation. Drilling is required. The BX8869 is available for the vehicle. Attachment Tabs are 20 inches center to center and a height of 25 inches.



1. Remove the two torx bolts from belly pan, just below tow hooks with the T-50 torx socket, both sides.



2. Loosen two metric bolts from back edge of belly pan with the 10MM socket, slide belly pan to the back of vehicle to release from slot and set aside.



3. Release the four tabs from the upper edge of grill by inserting flat screw driver into tab slot and rotating screw driver 1/4 of a turn while pulling grill forward to separate grill from tab.



4. Release the three tabs between the lower edge of grill and metal bumper, by inserting flat screw driver into tab slot and rotating screw driver 1/4 of a turn while pulling grill forward to separate grill from tab, set grill face down on a soft surface to prevent scratching.



5. Grill tabs will remain in radiator support front. Remove all grill tabs from radiator support and insert grill tabs into back side of grill openings to prepare for reinstallation later.



6. Just inside of headlight assembly are two metric bolts to remove with the 12MM socket, both sides.



Strong As An Ox™



7. Using the 12MM socket, remove metric hex nuts just forward of front tire on the back side of metal bumper, both sides.



9. Align bolt hole pattern of baseplate to the front of cross member (left photo of passenger's side view), both sides. Install the eight 10MM-1.25 x 35MM hex bolts, lock and flat washers through baseplate, into cross member and tighten. **Be sure to use loctite on all bolts before tightening. Tighten all bolts according to Torque Chart in General Instruction Sheet.**



10. Using the baseplate as a template, drill hole into the top of frame rail with the 17/32" drill bit, both sides (left photo). Slide spacer tube between baseplate and the top of frame to align with drill hole, both sides. Insert nut plate into hole in the bottom of frame rail to align with drilled hole (right photo). Tighten 1/2-13 x 2 1/2" hex bolt and lock washer into nut plate. **Be sure to use loctite on all bolts before tightening. Tighten all bolts according to Torque Chart in General Instruction Sheet.**



8. Remove the metric bolt from tow hook opening using the 10MM socket, pull metal bumper forward, disconnect all electrical components and set aside.







Strong As An Ox™

11. Reinstall metal bumper and upper grill. Be sure all electrical components are plugged in properly.
12. The dimensional variations between otherwise identical cars can be considerable. While the location and size of the holes in the baseplate were designed to allow for easy installation, it may be necessary to file a hole slightly to allow a bolt to clear.
13. Install the tow bar and safety cables according to the instructions included in their packages.
14. Do **not** substitute other devices if the tow bar pin and clip are lost.
15. **DEALER OR INSTALLER: BE CERTAIN THE USER RECEIVES THE INSTRUCTION SHEET.**

*Location for the  
Bx8869 on driver's side  
tail light assembly.*



### Tools Required

10MM Socket  
T-50 Torx Socket  
Flat Screw Driver

12MM Socket  
Loctite

3/4" Socket  
17/32" Drill Bit



Strong As An Ox™

### Parts List

Ref. No.	Qty.	Part No.	Description
1	1	61-6027	Weldment, Base Plate, BX1831
2	2	61-5496	1/2" Nut Plate, with 18" Wire
3	2	107-2681	Spacer Tube, BX1831
4	2	201-0153	1/2-13 x 2 1/2" Bolt, Grd. 5, ZP
5	2	203-0012	1/2" Lock Washer, ZP
6	8	201-0423	10MM-1.25 x 35MM Hex Bolt, Grd. 8.8, ZP
7	8	203-0104	10MM Lock Washer, ZP
8	8	203-0003	3/8" Flat Washer, ZP
9	2	201-0979	#12-14 X 1" Self Drilling Screw, ZP
10	2	202-0047	#10-32 Hex Nut
11	2	203-0054	#10 Lock Washer
12	2	201-0192	#10-32 x 1/2 Slot, Rd. Hd. Screw
13	2	101-5822	Adapter, 4 Way Connector
14	2	62-3468	Attachment, Assembly, SF/ SB (R)
	2	226-0046	Baseplate Safety Cable, 36" CL III (Not Shown)
	2	229-0359	Quicklink, 3/8, ZP (Not Shown)
	2	290-0437	Receiver, Cap Plug (BLK) (Not Shown)

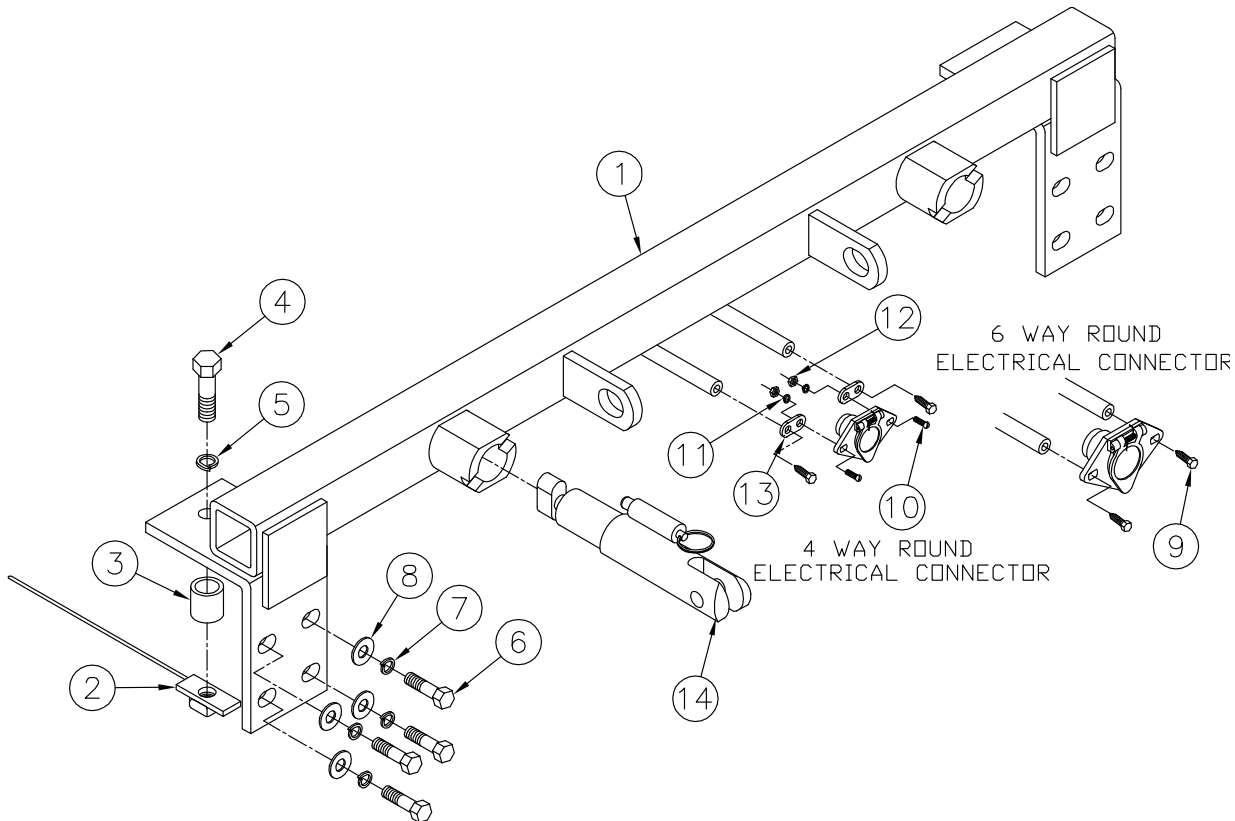

**IMPORTANT:** Use only genuine factory replacement parts on your Base Plate. Do not substitute homemade or nontypical parts. If a bolt is lost or in need of replacement, for your safety and the preservation of your Base Plate, be sure to use a replacement bolt of the same grade (Usually Grade 5, refer to parts list). Repair parts may be ordered through your nearest **Blue Ox** dealer or distributor.

# General Information

1. Ensure that your product(s) are registered online at [www.blueox.com](http://www.blueox.com). It is crucial to register your product(s) so that you may be alerted of product offerings, updates, upgrades, maintenance and safety bulletins, and/or recalls.
2. **It is the owner's responsibility to inspect all towing equipment for cracked welds, missing or worn parts and loose bolts before each towing trip.** Be sure to use Loctite® Red on all bolts and tighten to the recommended specifications.
3. **It is the owner's responsibility to hook up all towing equipment per manufacturer's instructions/recommendations.**
4. Remove the attachment tabs when not in use (if applicable).

## Notice To Baseplate Installer

### 1. It is YOUR responsibility to watch for:

- Oil cooler and air conditioner lines
- Electrical wires and hoses
- Missing parts or attaching points on the frame

\*\* If the baseplate is improperly installed and is against a wire or hose, it could cause fluid leaks or electrical shorts some time after the actual baseplate installation.

## Permanent Baseplate Safety Cable Installation

Permanent baseplate safety cables are strongly recommended when towing a vehicle with a tow bar. The principle function of the permanent baseplate safety cables is to prevent the towed vehicle from breaking loose in the event the connection between the frame of the towed vehicle and the baseplate fails or becomes disconnected. The cables must be connected from the baseplate to the frame rail or cross member of the vehicle's frame. The illustrations below show the possible arrangements recommended by Blue Ox®. Each permanent baseplate safety cable must have an adequate weight rating for the towing system. The weight rating of the two (2) cables together will not qualify.

***Do not mount the permanent baseplate safety cables against wires, hoses or brake lines.***

These permanent baseplate safety cables should remain installed as long as the baseplate is installed on the vehicle. Permanent baseplate safety cables are to be used in conjunction with, and NOT a replacement for legally required safety cables attaching the towed vehicle to the towing vehicle.

### OPTION #1

Permanent Baseplate Safety Cables to Cross Member or Frame of Towed Vehicle.

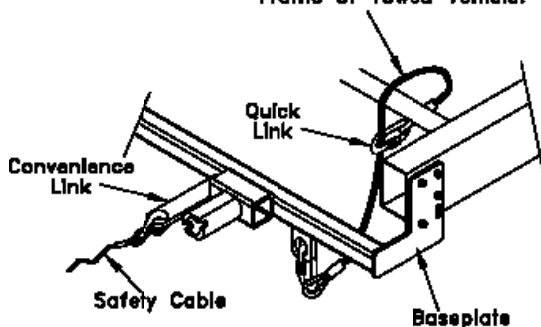

### OPTION #2

Permanent Baseplate Safety Cables to Cross Member or Frame of Towed Vehicle.

