



Strong As An Ox™

BX2168 Installation Instructions
2002-03 Ford E250 Van, V-8

Serial No.

The metal bumper, belly pan and horns are removed for baseplate installation. Drilling is required. Trimming of belly pan below metal bumper is required. The BX8869 is available for the vehicle. Attachment Tabs are 24 inches center to center and a height of 21 inches.



1. Remove two push pins from plastic belly pan and set aside. Using the 21MM socket, remove four metric bolts from the back side of the metal bumper and set bumper aside.

2. Remove two metric bolts from back side of horn assemblies with the 10MM socket, unplug electrical and set aside.



3. Slide baseplate from the bottom up to the frame and clamp in place with the vise grip, both sides. Using the baseplate as a template, drill the two bottom holes with the 17/32" drill bit, both sides. Insert 1/2" hex bolts into baseplate and drill holes, tighten 1/2" lock washer and hex nut. **Be sure and use loctite on all bolts before tightening. Tighten all bolts according to torque chart in the General Instruction sheet.**

4. Using the baseplate as a template, drill the remaining holes with the 17/32" drill bit, both sides. Insert backing plate into frame end to align with drilled holes and tighten 1/2" bolts, lock washers and hex nuts according to drawing on page two. **Be sure and use loctite on all bolts before tightening. Tighten all bolts according to torque chart in the General Instruction sheet.**



Strong As An Ox™

5. Reinstall horns and metal bumper. Hold belly pan in align to original position, trim as needed and reinstall.
6. The dimensional variations between otherwise identical cars can be considerable. While the location and size of the holes in the baseplate were designed to allow for easy installation, it may be necessary to file a hole slightly to allow a bolt to clear.
7. Install the tow bar and safety cables according to the instructions included in their packages.
8. Do **not** substitute other devices if the tow bar pin and clip are lost.
9. **DEALER OR INSTALLER: BE CERTAIN THE USER RECEIVES THE INSTRUCTION SHEET.**

*Location for the
Bx8869 on driver's side
tail light assembly.*





Tools Required

10MM Socket
21MM Socket
Utility Knife

Loctite
Vise Grips

17/32" Drill Bit
3/4" Socket

Parts List

Ref. No.	Qty.	Part No.	Description
1	1	61-5956	Weldment, Base Plate, BX2168
2	2	102-6472	Backing Plate, BX2168
3	10	201-0068	1/2-13 x 1 3/4 Bolt, Grd. 5, ZP
4	4	203-0005	1/2 Flat Washer, ZP
5	10	203-0012	1/2 Lock Washer, ZP
6	10	202-0005	1/2-13 Hex Nut, ZP
7	2	201-0979	#12-14 x 1" Self Drilling Screw, ZP
8	2	201-0192	#10-32 x 1/2 Slot, Rd. Hd. Screw
9	2	203-0054	#10 Lock Washer
10	2	202-0047	#10-32 Hex Nut
11	2	101-5822	Adapter, 4 Way Connector
	2	226-0049	Baseplate Safety Cable, 36" CL IV (Not Shown)
	2	229-0512	Quicklink, 1/2, ZP (Not Shown)

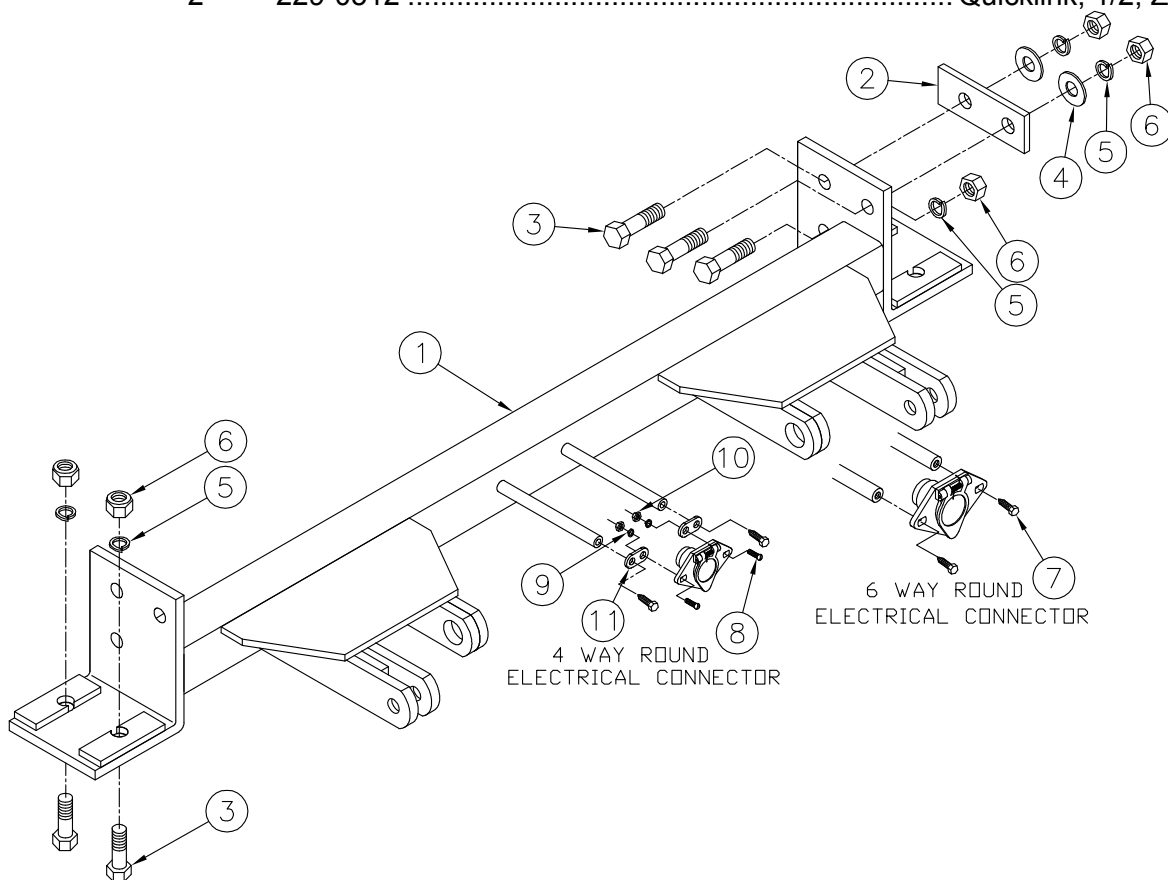

IMPORTANT: Use only genuine factory replacement parts on your Base Plate. Do not substitute homemade or nontypical parts. If a bolt is lost or in need of replacement, for your safety and the preservation of your Base Plate, be sure to use a replacement bolt of the same grade (Usually Grade 5, refer to parts list). Repair parts may be ordered through your nearest **Blue Ox** dealer or distributor.

General Information

1. Ensure that your product(s) are registered online at www.blueox.com. It is crucial to register your product(s) so that you may be alerted of product offerings, updates, upgrades, maintenance and safety bulletins, and/or recalls.
2. **It is the owner's responsibility to inspect all towing equipment for cracked welds, missing or worn parts and loose bolts before each towing trip.** Be sure to use Loctite® Red on all bolts and tighten to the recommended specifications.
3. **It is the owner's responsibility to hook up all towing equipment per manufacturer's instructions/recommendations.**
4. Remove the attachment tabs when not in use (if applicable).

Notice To Baseplate Installer

1. It is YOUR responsibility to watch for:

- Oil cooler and air conditioner lines
- Electrical wires and hoses
- Missing parts or attaching points on the frame

** If the baseplate is improperly installed and is against a wire or hose, it could cause fluid leaks or electrical shorts some time after the actual baseplate installation.

Permanent Baseplate Safety Cable Installation

Permanent baseplate safety cables are strongly recommended when towing a vehicle with a tow bar. The principle function of the permanent baseplate safety cables is to prevent the towed vehicle from breaking loose in the event the connection between the frame of the towed vehicle and the baseplate fails or becomes disconnected. The cables must be connected from the baseplate to the frame rail or cross member of the vehicle's frame. The illustrations below show the possible arrangements recommended by Blue Ox®. Each permanent baseplate safety cable must have an adequate weight rating for the towing system. The weight rating of the two (2) cables together will not qualify.

Do not mount the permanent baseplate safety cables against wires, hoses or brake lines.

These permanent baseplate safety cables should remain installed as long as the baseplate is installed on the vehicle. Permanent baseplate safety cables are to be used in conjunction with, and NOT a replacement for legally required safety cables attaching the towed vehicle to the towing vehicle.

OPTION #1

Permanent Baseplate Safety Cables to Cross Member or Frame of Towed Vehicle.

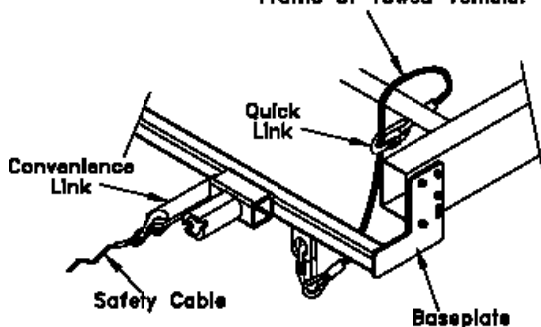

OPTION #2

Permanent Baseplate Safety Cables to Cross Member or Frame of Towed Vehicle.

