



Baseplate Installation Instructions

BX2188 2006-07 Lincoln Mark LT (4WD)

Installation Instructions

Serial Number

Please read BOTH these Installation Instructions and the General Towing Instructions before attempting to install or operate this equipment.

- Blue Ox® towing products and accessories are intended to be installed by Blue Ox® Dealers who are familiar with our products and have the equipment and knowledge to do “fit work”. When necessary, Blue Ox® Dealers can be found at www.blueox.us or by contacting our Customer Care Department at (888) 425-5382.
- Many Blue Ox® Baseplates are designed to use existing holes and hardware to mount the baseplate to the towed vehicle. Even though bolts are there, do not assume they are adequate for baseplate mounting. Always use hardware supplied in the hardware kit or existing hardware specified in the Baseplate Installation Instructions.

Attachment Tab Height: 22”
Attachment Tab Width: 22”

Bolt Torque Specifications
Torque in Foot-Pounds per Metric Bolts

Bolt Size	Grade 8.8	Grade 10.9
6MM	6	8
8MM	16	22
10MM	31	40
12MM	54	70
14MM	89	117

Confirm the towability and pre-towing procedures for your vehicle with the owner’s manual or contact the vehicle’s manufacturer for specific towing procedures.

Bolt Torque Specifications
Torque in Foot-Pounds per Inch Bolts

Bolt Size	Grade 5	Grade 8
1/4”	10	14
5/16”	19	29
3/8”	33	47
7/16”	54	78
1/2”	78	119
5/8”	154	230



! WARNING

Failure to read and follow these instructions could result in separation of the towed vehicle from the tow bar, causing property damage, loss of towed vehicle, personal injury or death.

BX2188
2006-07 Lincoln Mark LT (4WD)
Installation Instructions

Parts List

Ref. No.	Qty.	Part #	Description
1	1	61-6329	Weldment, Base Plate, BX2188
2	8	201-0051	1/2-13 x 1 1/2" Bolt, Grd. 5, ZP
3	2	106-0372	Tube, 3/4 od. x .095W. x 3/8"
4	8	203-0012	1/2" Lock Washer
5	8	202-0005	1/2-13 Hex Nut, ZP
6	2	201-0979	#12-14 x 1" Self Drilling Screw, ZP
7	2	201-0192	#10-32 x 1/2" Slot, Rd. Hd. Screw
8	2	203-0054	#10 Lock Washer
9	2	202-0047	#10-32 Hex Nut
10	2	101-5822	Adapter, 4 Way Connector
11	2	62-3468	Attachment Tab, SF/SB, ZP
	2	226-0049	Baseplate Safety Cable, 36" CL IV (Not Shown)
	2	229-0512	Quicklink, 1/2, ZP (Not Shown)
	2	290-0437	Receiver Cap Plug, Black (Not Shown)

Tools Required

Loctite® RED
8mm Socket
10mm Socket
21mm Socket
3/4" Socket
17/32" Drill Bit
Vise Grips

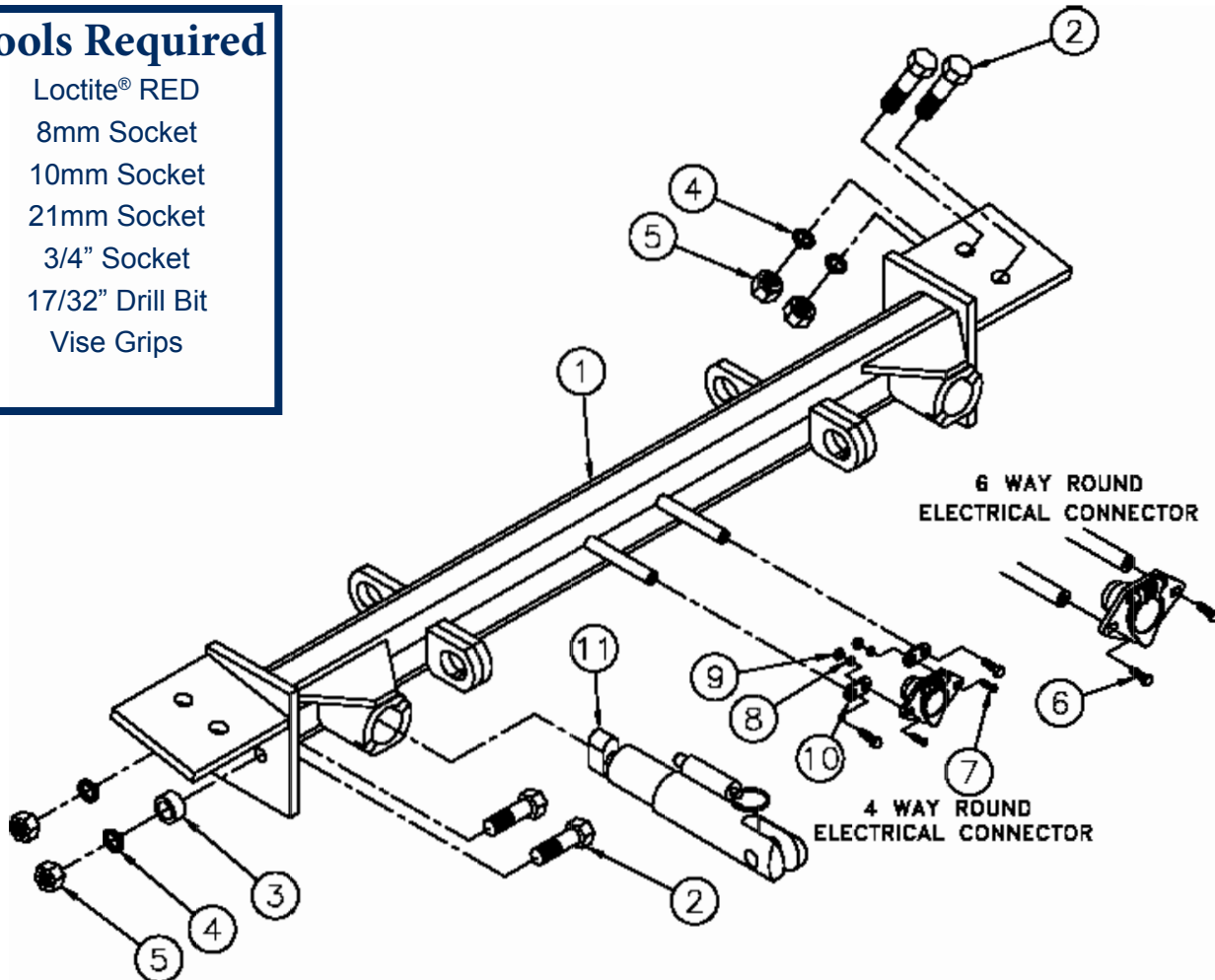

Important:

Use only genuine factory replacement parts on your baseplate. Do **NOT** substitute homemade or non-typical parts. If a bolt is lost or in need of replacement, for your safety and the preservation of your baseplate, be sure to use a replacement bolt of the same grade (In most cases it will be Grade 5, please reference the parts list above). Replacement parts may be ordered through your nearest Blue Ox® Dealer or Distributor.

BX2188

2006-07 Lincoln Mark LT (4WD)

Installation Instructions

Vehicle Weight:

The weight of this vehicle is near the Class III, 5,000 lbs. rating limitations. Some models, depending on options, may well exceed this 5,000 lb rating. Be sure to confirm the weight of your individual vehicle before towing. As of 1999 the Aventa® II is now rated 10,000 lbs. and either the Aventa® II or the Aventa® LX tow bar must be used for these applications.

Tow Bar Adapters are NOT to be used with vehicle's weighing over 5,000 lbs.

Installation Notes: The headlight assemblies, hood support brackets, bumper and metal bumper are removed for installation. Drilling is required.

The dimensional variations between otherwise identical vehicles can be considerable. While the baseplate was designed for easy installation, it may be necessary to tailor the baseplate slightly to compensate for auto manufacturer's tolerances. These minor adjustments may include filing a hole slightly, bending electrical rods, and/ or bending end plates.

The BX8869 Bulb and Socket Wiring Kit is recommended for this vehicle.

Installation Instructions:



1. Using the 10mm socket, remove one metric bolt on the upper corner of headlight assembly (see white arrow). Remove one pushpin from the air dam on top of the headlight assembly. Move air dam aside. Do this to both sides of the vehicle. Set bolts and pushpins aside to be reinstalled later.



2. Using the 10mm socket, remove two metric bolts from inside edge of headlight assembly (see white arrows). Raise the clip on upper corner of headlight assembly (see grey arrow). Pull headlight assembly forward to remove (releasing it from two clips behind assembly). Disconnect wiring. Do this to both sides of the vehicle. Set bolts and headlight assemblies aside to be reinstalled later.

BX2188
2006-07 Lincoln Mark LT (4WD)
Installation Instructions

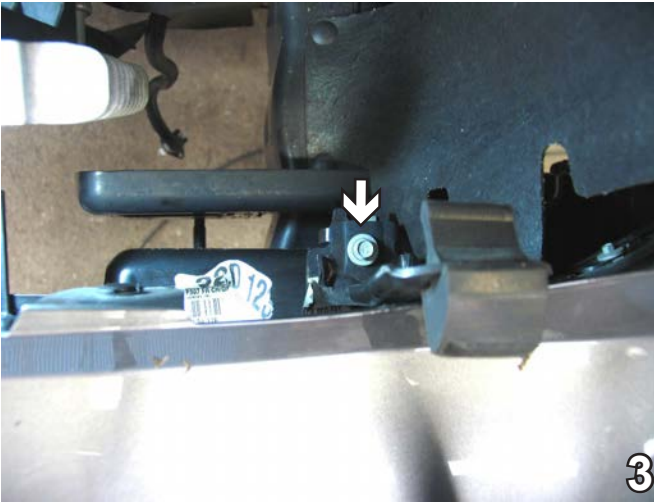

3. Behind front of fascia, on top of the frame, remove one metric bolt from the hood support bracket using the 10mm socket. Remove bracket. Do this to both sides of the vehicle. Set bolts and brackets aside to be reinstalled later.

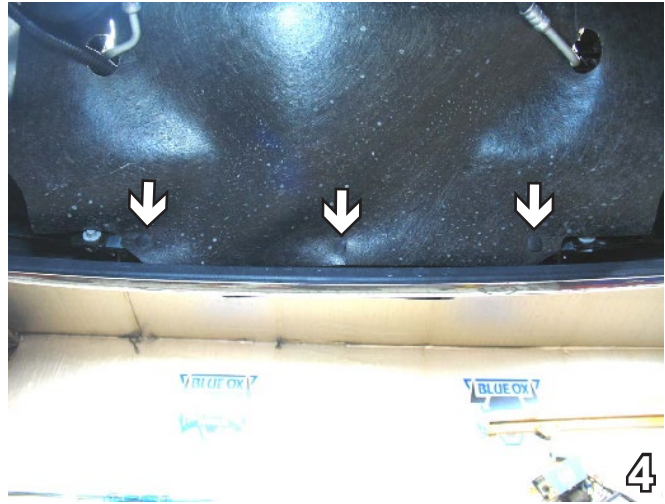

4. Remove three pushpins from metal bumper's lower edge and push air dam out of the way. Set pushpins aside to be reinstalled later.



5. Using the 10mm socket, remove one metric bolt from the top of fascia. Do this to both sides of the vehicle. Set bolts aside to be reinstalled later.



6. Remove one pushpin, just forward of the front tire, on the fender well. Do this to both sides of the vehicle. Set pushpins aside to be reinstalled later.

2006-07 Lincoln Mark LT (4WD)

Installation Instructions

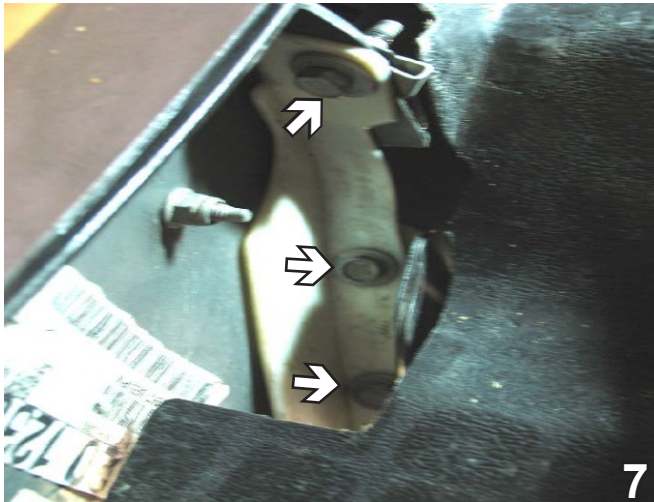

7. Under the fender, on fascia corner, remove three metric bolts using the 8mm socket. Do this to both sides of the vehicle. Set bolts aside to be reinstalled later.

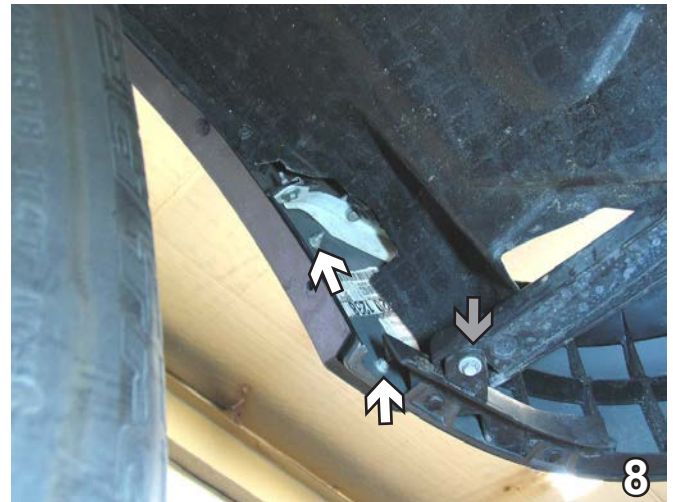

8. Using the 8mm socket, remove two metric hex nuts from the bottom corner of fascia (see white arrows). Using the 10mm socket, remove one metric bolt from the fascia extension (see grey arrow). Do this to both sides of the vehicle. Set nuts and bolts aside to be reinstalled later.



9. *Note: When removing metric bolts from behind the metal bumper, hold bumper securely as it is very heavy.* Using the 21mm socket remove lower metric bolt (see white arrow). Using the 10mm socket, remove upper metric bolt (see grey arrow). Disconnect fog lights if necessary. Do this to both sides of the vehicle. Set bolts aside to be reinstalled later.

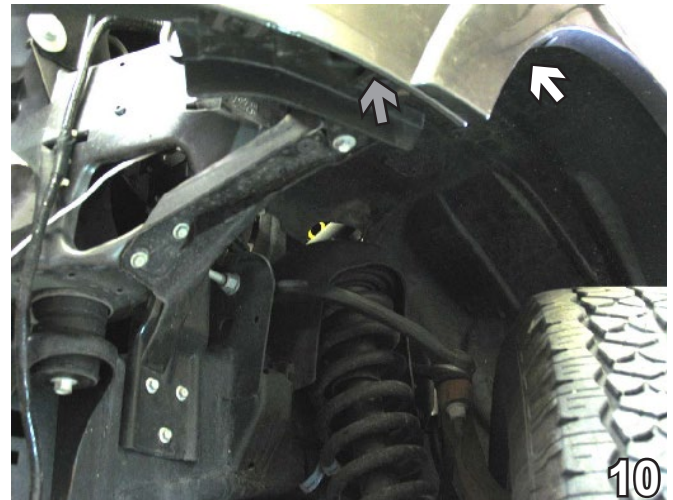

10. Pull on outer fascia trim (see white arrow) to separate it from the bumper. Pull bumper (see grey arrow) down and then forward to remove. Set bumper and metal bumper aside to be reinstalled later.

BX2188
2006-07 Lincoln Mark LT (4WD)
Installation Instructions

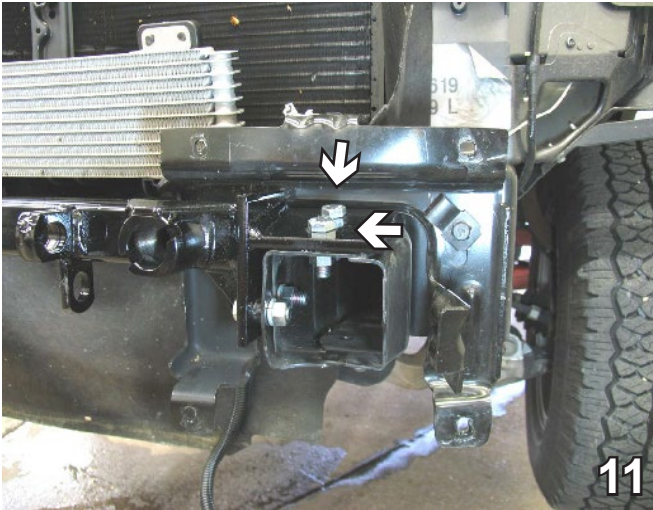

11. Slide baseplate on top of frame rail and align to end of frame rail. Clamp in place with the vise grips. Using the baseplate as a template, drill two holes in the top and side of frame rail using the 17/32" drill bit. On top, install the 1/2-13 x 1 1/2" bolts with 1/2" lock washers and 1/2-13 hex nuts and tighten. Do this to both sides of the vehicle.



12. Hold spacer tube between the baseplate and frame rail and align to the front hole on baseplate side (see white arrow). In front hole of baseplate, insert the 1/2-13 x 1 1/2" bolt through spacer tube and tighten to the 1/2" lock washer and 1/2-13 hex nut on side of baseplate. In back hole, install bolt, lock washer and hex nut and tighten (see grey arrow). Do this to both sides of the vehicle.

BE SURE TO USE LOCTITE® RED ON ALL BOLTS BEFORE TIGHTENING. TIGHTEN ALL BOLTS ACCORDING TO THE TORQUE CHART ON THE FRONT PAGE OF THESE INSTRUCTIONS OR ON PAGE 3 OF THE BASEPLATE TOWING GENERAL INSTRUCTIONS.

Be sure that ALL electrical connections are plugged in properly and functioning BEFORE installing the fascia.

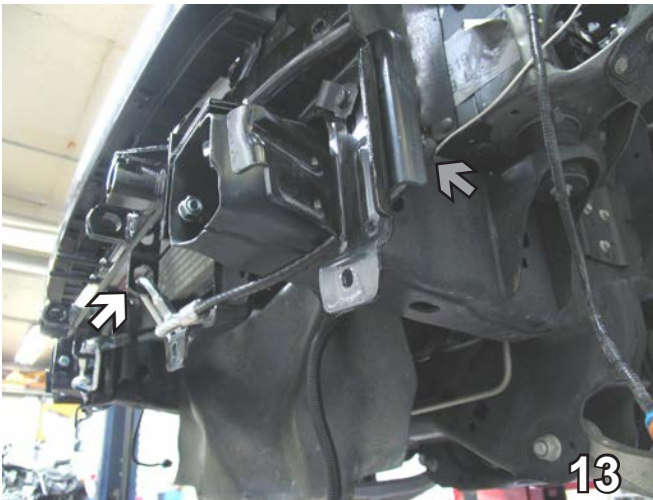

13. Attach the permanent baseplate safety cables to the provided convenience link on the baseplate (see white arrow). The photo above shows the recommended installation of the permanent baseplate safety cables to frame of the vehicle (see grey arrow). Additional options may interfere with suggested mounting, in this case, secure the cable to a solid piece of the frame as described in the instructions included with the permanent baseplate safety cables. Be sure the safety cables do not rub against any hoses or moving parts.

14. Reinstall metal bumper, bumper, hood support brackets, headlight assemblies, bolts and pushpins.

Install the tow bar and safety cables according to the instructions provided in their packages. When demonstrating this to the customer, be sure to include all the contents and packages.

Do **NOT** substitute other devices if the tow bar pins and clips are misplaced.

**DEALER or INSTALLER:
Be certain the user receives the instruction sheets for their products.**

BX2188
2006-07 Lincoln Mark LT (4WD)
Installation Instructions



CUSTOMER SERVICE COMMITMENT

Blue Ox is committed to providing you with exceptional customer care throughout your lifetime with our products. Our team is here to assist you with any questions you may have regarding the performance of your product. Simply call 1-800-228-9289 and you can speak with our customer care team.

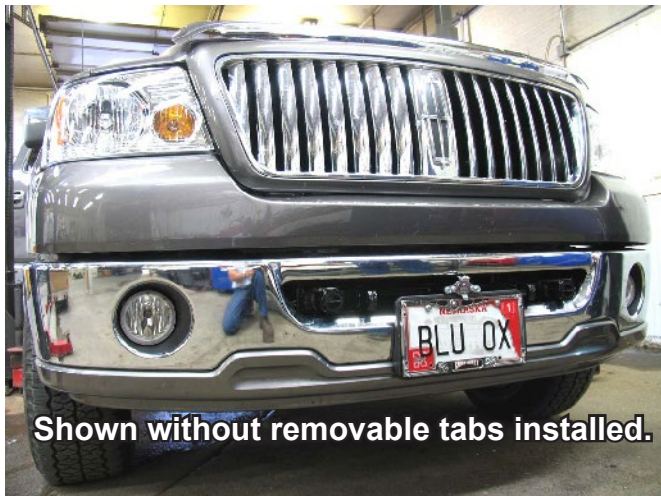

Additionally, please visit our website to see which rallies our Destination America team will be attending. For a nominal fee, our service technician will service your towing system to ensure it's in proper working condition. Also as a commitment to our customers, should you visit our factory you can stay at our full service Blue Ox campground at no charge along with enjoying a factory tour.

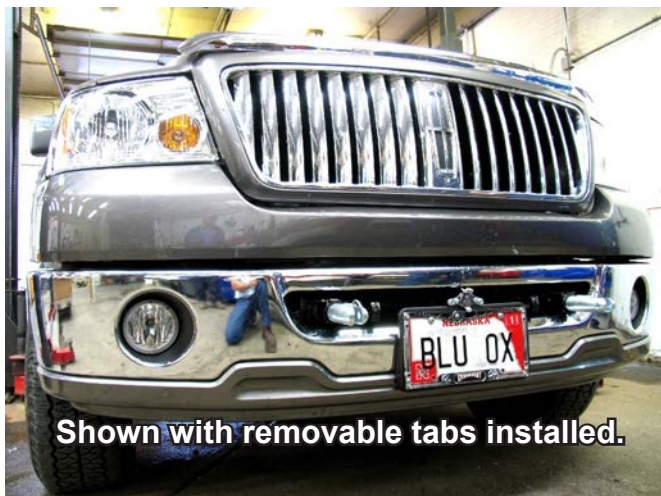

Again thank you for being our customer and for the confidence you have shown in the performance of our products. It is because of customers like you we enjoy the success we have today.



© 2006, 09 Blue Ox
One Mill Road, Industrial Park
Pender, Nebraska 68047
Phone: (402) 385-3051 • Fax: (402) 385-3360
www.blueox.us
1/16/18

General Information

1. Ensure that your product(s) are registered online at www.blueox.com. It is crucial to register your product(s) so that you may be alerted of product offerings, updates, upgrades, maintenance and safety bulletins, and/or recalls.
2. **It is the owner's responsibility to inspect all towing equipment for cracked welds, missing or worn parts and loose bolts before each towing trip.** Be sure to use Loctite® Red on all bolts and tighten to the recommended specifications.
3. **It is the owner's responsibility to hook up all towing equipment per manufacturer's instructions/recommendations.**
4. Remove the attachment tabs when not in use (if applicable).

Notice To Baseplate Installer

1. It is YOUR responsibility to watch for:

- Oil cooler and air conditioner lines
- Electrical wires and hoses
- Missing parts or attaching points on the frame

** If the baseplate is improperly installed and is against a wire or hose, it could cause fluid leaks or electrical shorts some time after the actual baseplate installation.

Permanent Baseplate Safety Cable Installation

Permanent baseplate safety cables are strongly recommended when towing a vehicle with a tow bar. The principle function of the permanent baseplate safety cables is to prevent the towed vehicle from breaking loose in the event the connection between the frame of the towed vehicle and the baseplate fails or becomes disconnected. The cables must be connected from the baseplate to the frame rail or cross member of the vehicle's frame. The illustrations below show the possible arrangements recommended by Blue Ox®. Each permanent baseplate safety cable must have an adequate weight rating for the towing system. The weight rating of the two (2) cables together will not qualify.

Do not mount the permanent baseplate safety cables against wires, hoses or brake lines.

These permanent baseplate safety cables should remain installed as long as the baseplate is installed on the vehicle. Permanent baseplate safety cables are to be used in conjunction with, and NOT a replacement for legally required safety cables attaching the towed vehicle to the towing vehicle.

OPTION #1

Permanent Baseplate Safety Cables to Cross Member or Frame of Towed Vehicle.

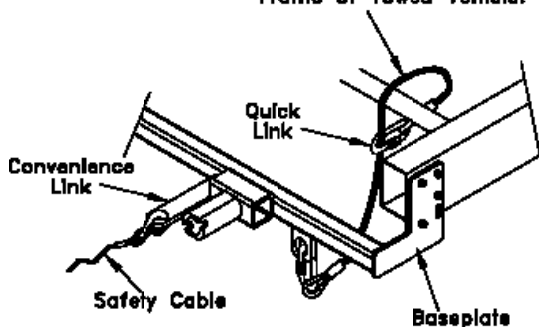

OPTION #2

Permanent Baseplate Safety Cables to Cross Member or Frame of Towed Vehicle.

