

Please read **BOTH** these Installation Instructions and the General Towing Instructions before attempting to install or operate this equipment.

- Blue Ox® towing products and accessories are intended to be installed by Blue Ox® Dealers who are familiar with our products and have the equipment and knowledge to do “fit work”. When necessary, Blue Ox® Dealers can be found at www.blueox.com or by contacting our Customer Care Department at (402) 385-3051.
- Many Blue Ox® Baseplates are designed to use existing holes and hardware to mount the baseplate to the towed vehicle. Even though bolts are there, do not assume they are adequate for baseplate mounting. Always use hardware supplied in the hardware kit or existing hardware specified in the Baseplate Installation Instructions.

Attachment Tab Height: 17 1/2”
Attachment Tab Width: 20”

Bolt Torque Specifications

Torque in Foot-Pounds for Metric Bolts

Bolt Size	Grade 8.8	Grade 10.9
6MM	6	8
8MM	16	22
10MM	31	40
12MM	54	70
14MM	89	117

Confirm the towability and pre-towing procedures for your vehicle with the owner’s manual or contact the vehicle’s manufacturer for specific towing procedures.

Bolt Torque Specifications

Torque in Foot-Pounds for Inch Bolts

Bolt Size	Grade 5	Grade 8
1/4”	10	14
5/16”	19	29
3/8”	33	47
7/16”	54	78
1/2”	78	119
5/8”	154	230



If the front of your vehicle looks different than this, call us at (402) 385-3051.

! WARNING

Failure to read and follow these instructions could result in separation of the towed vehicle from the tow bar, causing property damage, loss of towed vehicle, personal injury or death.

BX2524

2008-11 Mazda Tribute

Installation Instructions

Parts List

Ref. No.	Qty.	Part #	Description
1	1	61-6558	WELDMENT, BASEPLATE, BX2524
2	10	201-0518	10MM-1.5 X 40MM HEX BLT,GR 10.9, ZP
3	10	203-0104	10MM LOCK WASHER, ZP.
4	4	203-0103	10MM FLAT WASHER, ZP.
5	4	EXISTING	EXISTING METRIC BOLTS
6	4	201-0440	3/8-16 X 1 1/2 HEX BOLT, GRD.5, ZP
7	4	201-0444	3/8-16 X 2 HEX BOLT GRADE 5 ZP.
8	8	203-0010	3/8 LOCK WASHER, ZP
9	2	203-0003	3/8 FLAT WASHER, ZP
10	8	61-5208	WLD, NUT PLT, 1/4X1X1, 3/8"/14"WIRE
11	2	201-0979	#12-14 x 1" Self Drilling Screw, ZP
12	2	201-0192	10-32 X 1/2 SLOT, RD. HD. SCREW
13	2	203-0054	#10 LOCK WASHER
14	2	202-0047	#10-32 HEX NUT
15	2	101-5822	ADAPTER, 4 WAY CONNECTOR
16	2	62-3468	ATT TAB ASSY, REM, SF/SB, 1 HOLE
	2	226-0046	BASEPLATE SAFETY CABLE, 36" CL III (Not Shown)
	2	229-0359	QUICKLINK, 3/8, ZP (Not Shown)
	2	290-0437	RECEIVER, CAP PLUG (BLK) (Not Shown)
E	14		Existing Metric Bolts

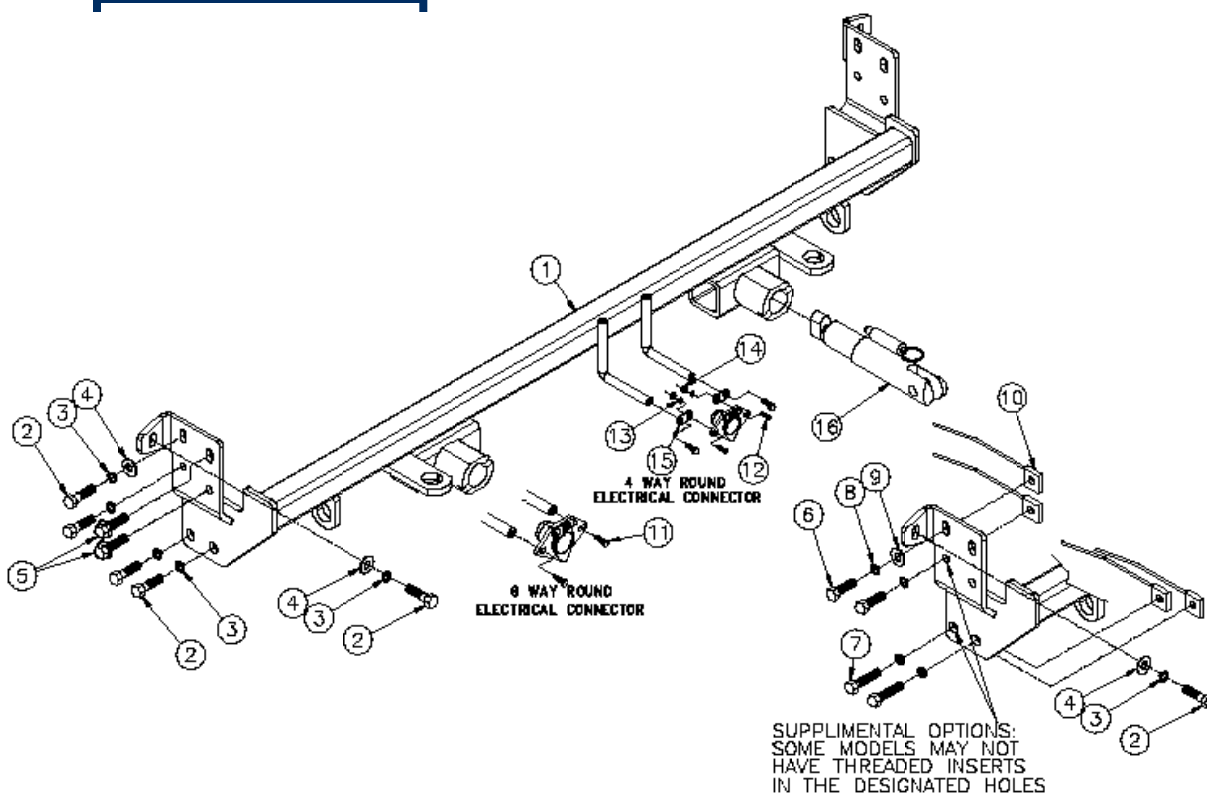

Important:

Use only genuine factory replacement parts on your baseplate. Do **NOT** substitute homemade or non-typical parts. If a bolt is lost or in need of replacement, for your safety and the preservation of your baseplate, be sure to use a replacement bolt of the same grade (In most cases it will be Grade 5, please reference the parts list above). Replacement parts may be ordered through your nearest Blue Ox® Dealer or Distributor. Failing to follow and/or altering these installation instructions in either installation or required equipment will void the manufacturer's warranty.

BX2524

2008-11 Mazda Tribute

Installation Instructions

Attachment Tabs:

Motorhome mount tow bars are recommended for use with this baseplate. Due to the design of the removable tabs, the RangeFinderII and Ambassador tow bars can not be used. Adapters, except the BX8833 and BX88151, can not be used with this baseplate.

Installation Notes: The bumper and fascia are removed for installation. The bumper core is not reinstalled.

The dimensional variations between otherwise identical vehicles can be considerable. While the baseplate was designed for easy installation, it may be necessary to tailor the baseplate slightly to compensate for auto manufacturer's tolerances. These minor adjustments may include filing a hole slightly, bending electrical rods or bending end plates.

The BX8869 Bulb and Socket Wiring Kit is recommended for this vehicle.



Handling of some cosmetic parts when installing this product may require the use of protective covers, rags, specialty tools, etc. to prevent damage.

Installation Instructions:



1. On the upper corner of grille, use the 10mm socket to remove one metric bolt. Do this to both sides of the vehicle. Set bolts aside to be reinstalled later.



2. Just forward of the front tire, inside the wheel well, remove three Phillips push pins. Do this to both sides of the vehicle. Set push pins aside to be reinstalled later.

BX2524
2008-11 Mazda Tribute
Installation Instructions



3. Using the 10mm socket, remove two metric bolts from bottom corner of fascia, just forward of front tire. Do this to both sides of the vehicle. Set bolts aside to be reinstalled later.



4. Remove three bolts from across the bottom corner of the fascia, using the 10mm socket. Set bolts aside to be reinstalled later.



5. Reach in behind the fascia and push the clip holding the fascia down to release. Do this to both sides of the vehicle.



6. Pop out the push pin on the front corner of the fascia. Do this to both sides of the vehicle. Set the push pin aside to reinstall later.

7. Under the front of the fascia, remove a Phillips pushpin on each side of the license plate. Pull the fascia forward to remove. Set push pins and fascia aside carefully to be reinstalled later.



BX2524
2008-11 Mazda Tribute
Installation Instructions

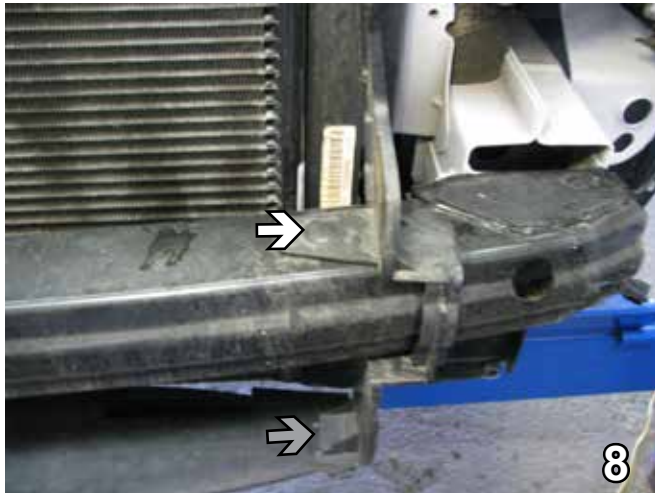

8. Using the flat screw driver, remove push pin from the piece of plastic on the outside of the bumper. Unhook the plastic from the top and the bottom (gray arrow). Do this to both sides of the vehicle. Set aside to be reinstalled later.

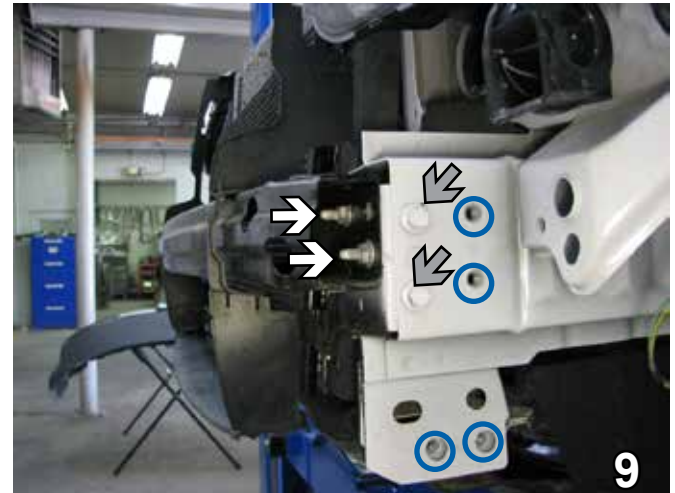

9. Remove the two nuts holding the bumper on with a 13mm socket. Do this on both sides. The bumper core is removed and not reinstalled. Set the nuts and bumper aside to reinstall later. The two bolts on each side (gray arrows) are removed with a 13mm socket and will be used to attach the baseplate. Note: Some vehicles may not have these holes (circled) with threaded inserts, see supplemental options on page 2 for hardware conversion.

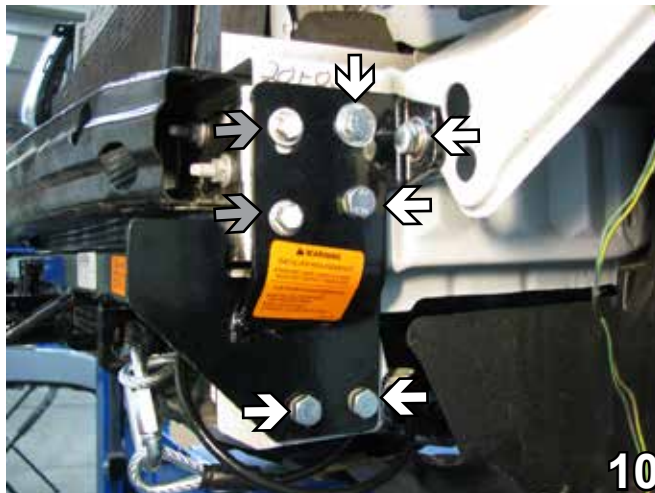

10. Align the baseplate with the seven existing holes in the frame. Insert the existing bolts (gray arrows) with Loctite into the baseplate and tighten. Use 10MM-1.5 x 40MM hex bolts with Loctite and 10MM lock washers in all the holes. In the top two also use a 10MM flat washer. Do this to both sides of the vehicle.

BE SURE TO USE LOCTITE® RED ON ALL BOLTS BEFORE TIGHTENING. TIGHTEN ALL BOLTS ACCORDING TO THE TORQUE CHART ON THE FRONT PAGE OF THESE INSTRUCTIONS OR ON PAGE 3 OF THE BASEPLATE TOWING GENERAL INSTRUCTIONS.



11. Attach the permanent baseplate safety cables to the provided convenience link on the baseplate (see grey arrow). The photo above shows the recommended installation of the cables to frame of vehicle (see white arrow). Additional options may interfere with suggested mounting; in this case secure the cables to a solid piece of the frame as described in the instructions included with the permanent baseplate safety cables. Be sure the safety cables do not rub against any hoses or moving parts. Do this to both sides of the vehicle.

BX2524
2008-11 Mazda Tribute
Installation Instructions

12. Reinstall push pins, bolts, bumper and fascia.
The bumper core is not reinstalled.

Be sure that **ALL** electrical connections are plugged in properly and functioning **BEFORE** Installing the fascia.

DEALER or INSTALLER:

Be certain the user receives the instruction sheets for their products.

Install the tow bar and safety cables according to the instructions provided in their packages. When demonstrating this to the customer, be sure to include all the contents and packages.

Do **NOT** substitute other devices if the tow bar pins and clips are misplaced.

CUSTOMER SERVICE COMMITMENT

Blue Ox is committed to providing you with exceptional customer care throughout your lifetime with our products. Our team is here to assist you with any questions you may have regarding the performance of your product. Simply call 1-(402) 385-3051 and you can speak with our customer care team.

Additionally, please visit our website to see which rallies our Destination America team will be attending. For a nominal fee, our service technician will service your towing system to ensure it's in proper working condition. Also as a commitment to our customers, should you visit our factory you can stay at our full service Blue Ox campground at no charge along with enjoying a factory tour.

Again thank you for being our customer and for the confidence you have shown in the performance of our products. It is because of customers like you we enjoy the success we have today.



If the baseplate is in an accident, it must be replaced. **DO NOT** use it again! An accident can cause unseen damage and using it again could result in more damage or serious injury. **DO NOT** use the baseplate if it is damaged or missing parts.



© 2008, 09, 10, 11 Blue Ox
One Mill Road, Industrial Park
Pender, Nebraska 68047
Phone: (402) 385-3051 • Fax: (402) 385-3360
www.blueox.com

General Information

1. Ensure that your product(s) are registered online at www.blueox.com. It is crucial to register your product(s) so that you may be alerted of product offerings, updates, upgrades, maintenance and safety bulletins, and/or recalls.
2. **It is the owner's responsibility to inspect all towing equipment for cracked welds, missing or worn parts and loose bolts before each towing trip.** Be sure to use Loctite® Red on all bolts and tighten to the recommended specifications.
3. **It is the owner's responsibility to hook up all towing equipment per manufacturer's instructions/recommendations.**
4. Remove the attachment tabs when not in use (if applicable).

Notice To Baseplate Installer

1. It is YOUR responsibility to watch for:

- Oil cooler and air conditioner lines
- Electrical wires and hoses
- Missing parts or attaching points on the frame

** If the baseplate is improperly installed and is against a wire or hose, it could cause fluid leaks or electrical shorts some time after the actual baseplate installation.

Permanent Baseplate Safety Cable Installation

Permanent baseplate safety cables are strongly recommended when towing a vehicle with a tow bar. The principle function of the permanent baseplate safety cables is to prevent the towed vehicle from breaking loose in the event the connection between the frame of the towed vehicle and the baseplate fails or becomes disconnected. The cables must be connected from the baseplate to the frame rail or cross member of the vehicle's frame. The illustrations below show the possible arrangements recommended by Blue Ox®. Each permanent baseplate safety cable must have an adequate weight rating for the towing system. The weight rating of the two (2) cables together will not qualify.

Do not mount the permanent baseplate safety cables against wires, hoses or brake lines.

These permanent baseplate safety cables should remain installed as long as the baseplate is installed on the vehicle. Permanent baseplate safety cables are to be used in conjunction with, and NOT a replacement for legally required safety cables attaching the towed vehicle to the towing vehicle.

OPTION #1

Permanent Baseplate Safety Cables to Cross Member or Frame of Towed Vehicle.

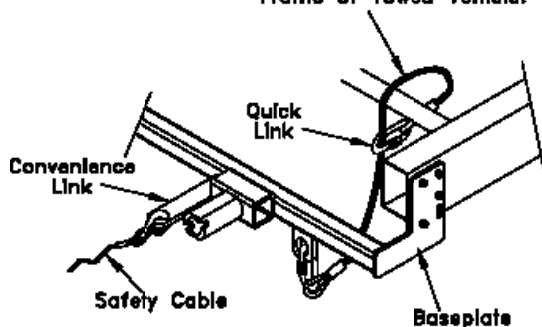

OPTION #2

Permanent Baseplate Safety Cables to Cross Member or Frame of Towed Vehicle.

