



**BLUE OX®**

Baseplate Installation Instructions

BX2321

# 2006-10 Hyundai Sonata Installation Instructions

Serial Number

**Please read BOTH these Installation Instructions and the General Instructions before attempting to install or operate this equipment.**

1. Blue Ox® towing products and accessories are intended to be installed by Blue Ox® Dealers who are familiar with our products and have the necessary equipment and knowledge to do "fit work". When necessary Blue Ox® Dealers can be found at [www.blueox.com](http://www.blueox.com) or by contacting our Customer Care Department at (402) 385-3051.
2. Many Blue Ox® baseplates are designed to use existing holes and hardware to mount the baseplate to the towed vehicle. Even though bolts are there, do not assume they are adequate for baseplate mounting. Always use hardware supplied in the hardware kit and existing hardware specified in the Baseplate Installation Instructions.

Attachment Tab Height: 16"

Attachment Tab Width: 24"

**Bolt Torque Specifications**  
Torque in Foot-Pounds for Metric Bolts

Bolt Size	Grade 8.8	Grade 10.9
6MM	6	8
8MM	16	22
10MM	31	40
12MM	54	70
14MM	89	117

Confirm the towability and pre-towing procedures for your vehicle with the owner's manual or contact the vehicle's manufacturer for specific towing procedures.

**Bolt Torque Specifications**  
Torque in Foot-Pounds for Inch Bolts

Bolt Size	Grade 5	Grade 8
1/4"	10	14
5/16"	19	29
3/8"	33	47
7/16"	54	78
1/2"	78	119
5/8"	154	230

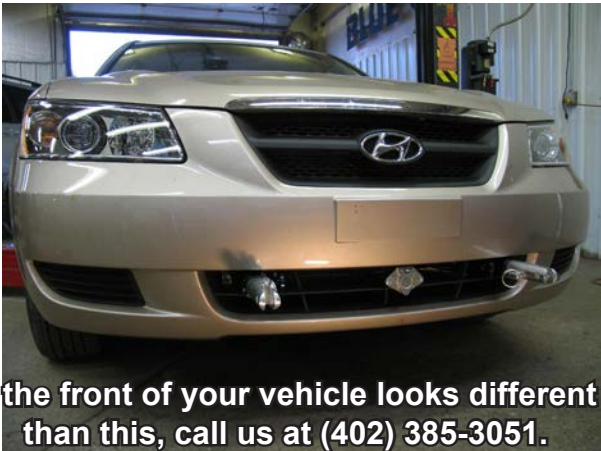

If the front of your vehicle looks different than this, call us at (402) 385-3051.

**! WARNING**  
Failure to read and follow these instructions could result in separation of the towed vehicle from the tow bar, causing property damage, loss of towed vehicle, personal injury or death.

# BX2321

## 2006-10 Hyundai Sonata

### Installation Instructions

### Parts List

Ref. No.	Qty.	Part #	Description
1	1	61-6171	Weldment, Baseplate, BX2321
2	7	61-5208	Weldment, 3/8-16 Nut Plate, w/ 14" Wire
3	7	201-0440	3/8-16 x 1 1/2" Hex Bolt, Grd. 5, ZP
4	2	201-0443	3/8-16 x 1" Hex Bolt, Grd 5, ZP
5	2	203-0003	3/8" Flat Washer, ZP
6	9	203-0010	3/8" Lock Washer, ZP
7	2	202-0003	3/8-16 Hex Nut, ZP
8	2	201-0702	6MM-1.00 x 45MM Hex Bolt, Grd 8.8, ZP
9	2	203-0161	6MM Lock Washer, ZP
10	9	203-0001	1/4" Flat Washer, ZP
11	3	201-0654	#10-16 X 1 Self Drilling Screw
12	2	201-0979	#12-14 x 1" Self Drilling Screw, ZP
13	2	201-0192	#10-32 x 1/2 Slot, Rd. Hd. Screw
14	2	203-0054	#10 Lock Washer
15	2	202-0047	#10-32 Hex Nut
16	2	101-5822	Adapter, 4 Way Connector
17	2	62-3469	Attachment, Assembly, SF/LB (R)
	2	226-0046	Baseplate Safety Cable, 36" CL III (Not Shown)
	2	229-0359	Quicklink, 3/8, ZP (Not Shown)
	2	290-0437	Cap Plug (Not Shown)

### Tools Required

10MM Socket	Loctite Red
12MM Socket	Reciprocating Saw
Phillips Screw Driver	9/16" Socket
Utility Knife	Vice Grip
1 1/4" Hole Saw	13/32" Socket

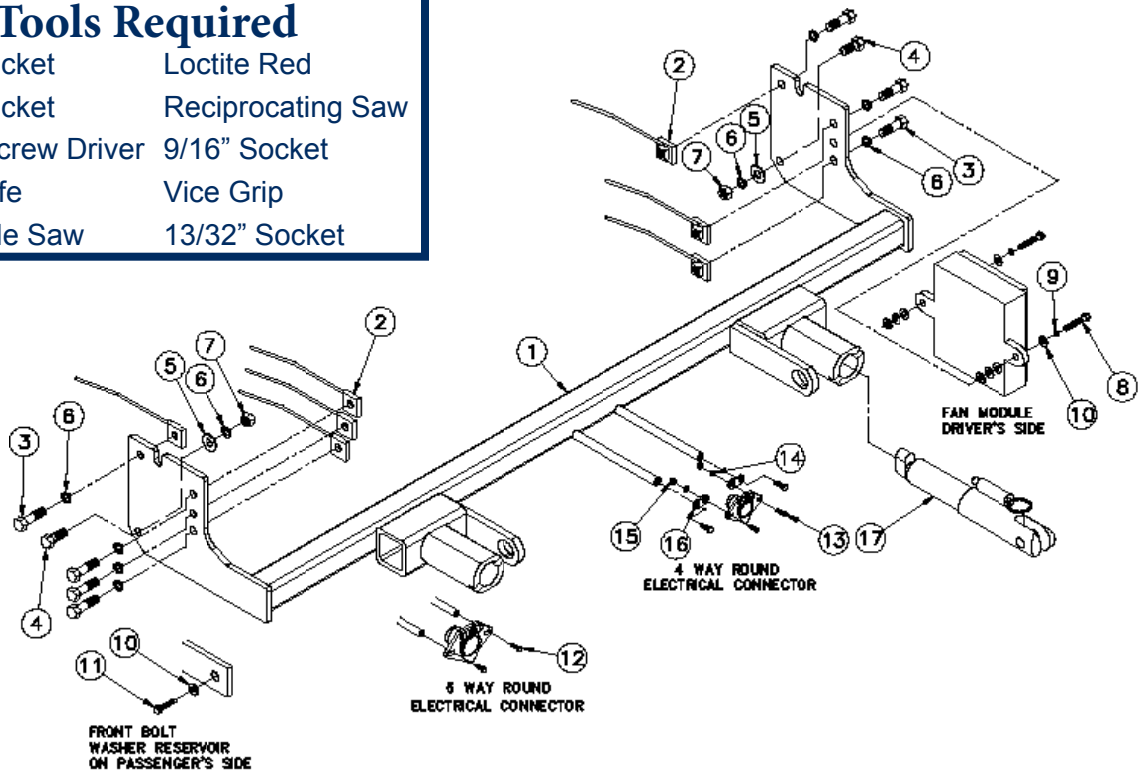

### Important:

Use only genuine factory replacement parts on your baseplate. Do NOT substitute homemade or non-typical parts. If a bolt is lost or in need of replacement, for your safety and the preservation of your baseplate, be sure to use a replacement bolt of the same grade. In most cases it will be Grade 5—please reference the parts list above. Replacement parts may be ordered through your nearest Blue Ox® dealer or distributor, or call our Customer Care Team at (402)385-3051. Failing to follow and/or altering these installation instructions in either installation or required equipment will void the manufacturer's warranty. Towing behind a non-motorized vehicle will void the warranty.

# BX2321

## 2006-10 Hyundai Sonata

### Installation Instructions

#### Attachment Tabs:

Due to the design of the removable tabs, the RangeFinder II tow bars can not be used. Adapters, except for the BX8833 and the BX88151, can not be used with this baseplate.

#### Instructions:

The front fascia, metal bumper, air dam, horn bracket and belly pan are removed and reinstalled during baseplate installation. Drilling is required. Trimming of the air dam and bumper bracket is required.

The dimensional variations between otherwise identical vehicles can be considerable. Although the baseplate was designed for easy installation, it may be necessary to tailor the baseplate slightly to compensate for auto manufacturer's tolerances. These minor adjustments may include filing a hole slightly, bending electrical rods or bending end plates.

The BX8869 Bulb and Socket Wiring Kit is recommended for this vehicle.



The BX8869 Bulb & Socket Wiring Kit is recommended to be used with this vehicle.

#### Installation Instructions:

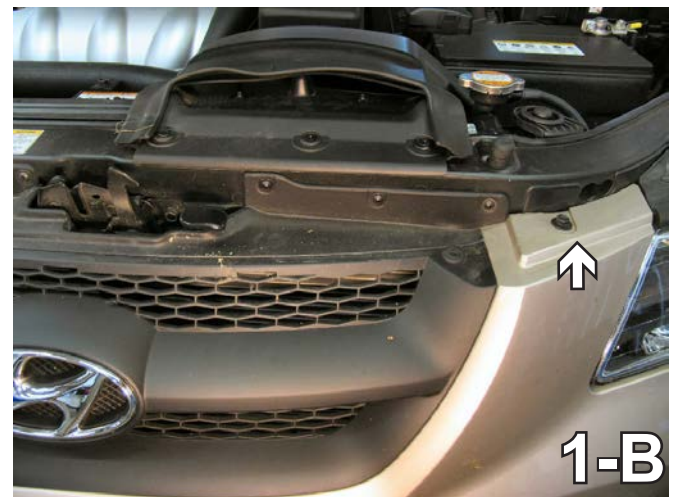
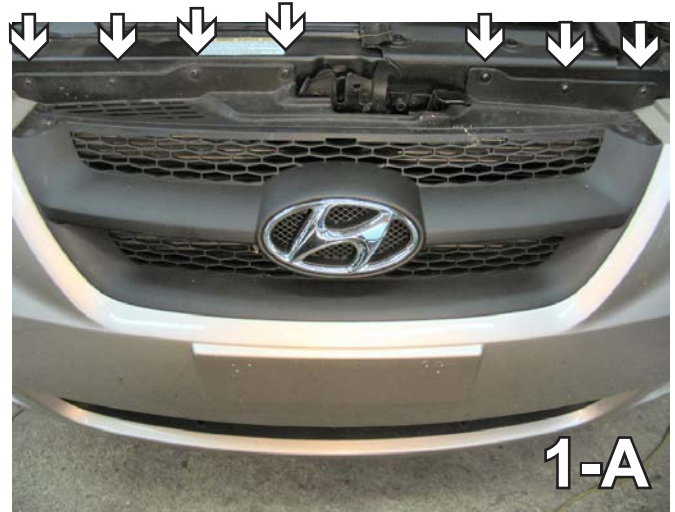

1. Remove seven Phillips screws from the top edge of the front fascia, as indicated by the white arrows in photo 1-A. Remove two bolts from the top side of the fascia using a 10MM socket, as indicated by the arrow in photo 1-B. Set push pins and bolts aside to be reinstalled later.

Handling of some cosmetic parts when installing this product may require the use of protective covers, rags, specialty tools, etc. to prevent damage.

BX2321  
2006-10 Hyundai Sonata  
Installation Instructions



2. Remove two Phillips push pins on the underneath corner of fascia, just forward of the wheel well. Do this to both sides of the vehicle. Set push pins aside to be reinstalled later.



3. Using a 10MM socket, remove one bolt from the front fascia, inside the wheel well. Do this to both sides of the vehicle. Set bolts aside to be reinstalled later.



4. If necessary, use a utility knife to cut the wheel well trim so the fascia may be removed. Pull the front fascia forward and set it aside carefully.



5. Using a 10MM socket, remove one bolt from the horn bracket, as indicated by the white arrow. Disconnect the wire, as indicated by the grey arrow. Set horn aside to be reinstalled later.

BX2321  
2006-10 Hyundai Sonata  
Installation Instructions



6. Remove three clips from electrical cable. Move the cable aside to clear area for baseplate installation.

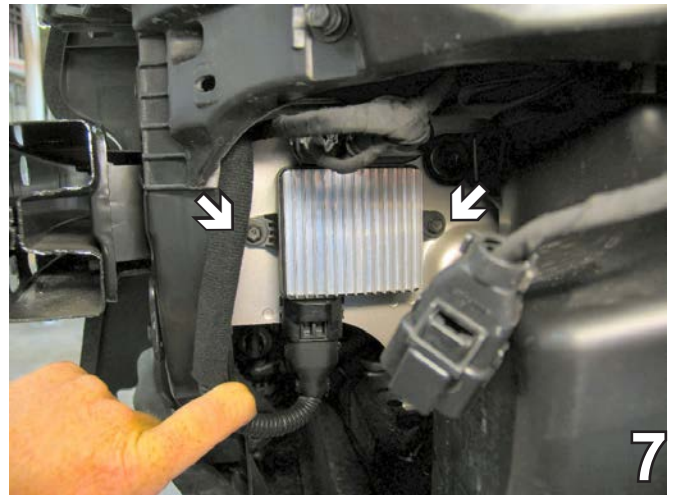

7. On the driver's side, just behind the metal bumper, remove two bolts with the 10MM socket and set the fan controller and bolts aside to be reinstalled later.

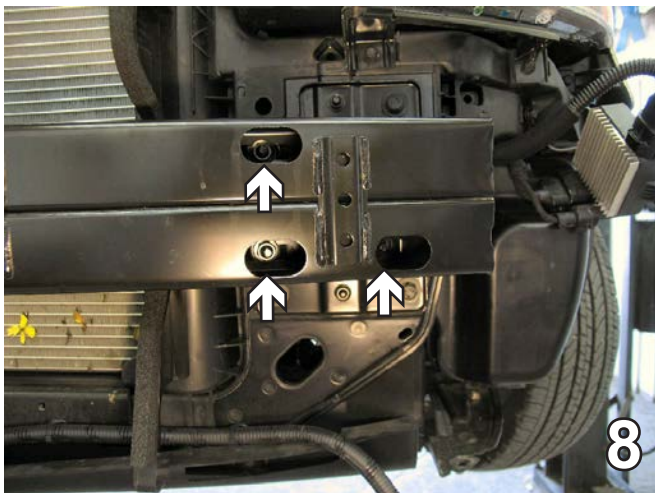

8. Using the 12MM socket, remove three bolts from the metal bumper and set aside to be reinstalled later. Do this to both sides of the vehicle. Release clips and remove air dam from the side of the radiator. Do this to both sides of the vehicle.

# BX2321

## 2006-10 Hyundai Sonata

### Installation Instructions

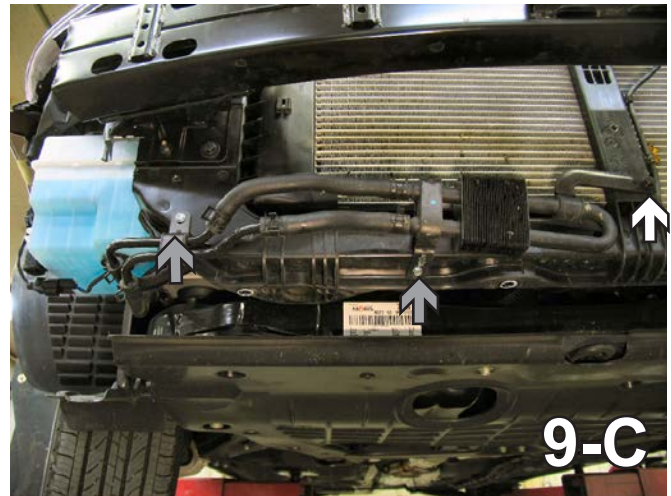
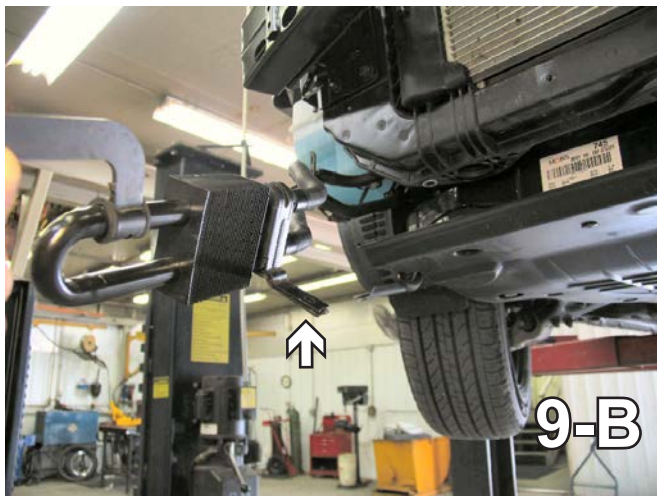
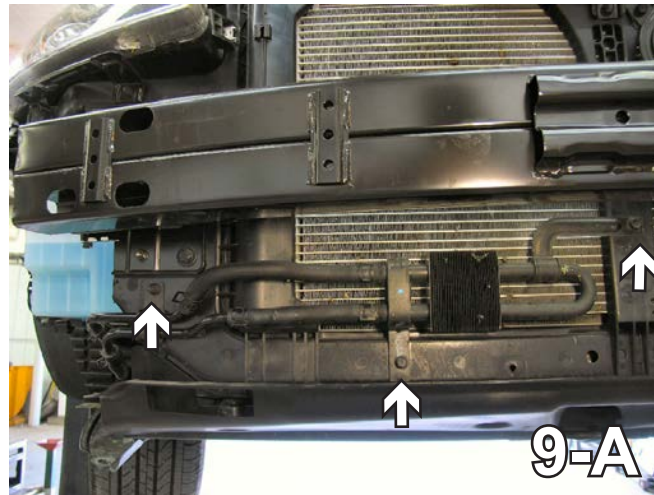

9. Using the 10MM socket, remove three bolts from coolant tubing (see 9-A). Relocate driver's side bolt to lower existing threaded hole in coolant tubing bracket. Bend middle coolant tube bracket 90 degrees toward the radiator (see 9-B). Refasten using two self drilling screws (gray arrows). Photo 9-C shows relocated coolant tubing.

BX2321  
2006-10 Hyundai Sonata  
Installation Instructions

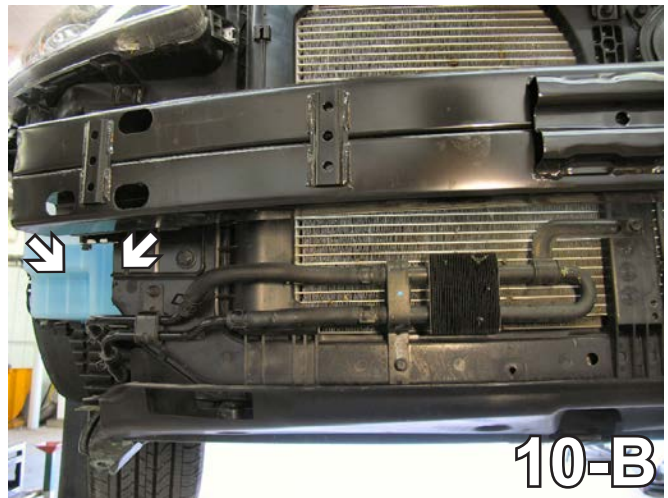
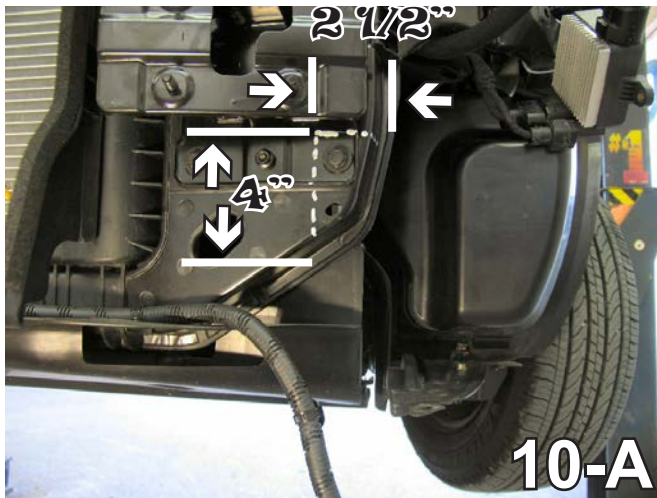

10. Using a reciprocating saw, trim horizontally 2 1/2" just behind the bumper bracket from the outside edge of the radiator support into the frame rail edge. Trim vertically 4" from the bottom, of the radiator support to the horizontal to open area for baseplate installation. Do this to both sides of the vehicle.

Using a good quality paint, spray cut edges of frame to prevent rusting.

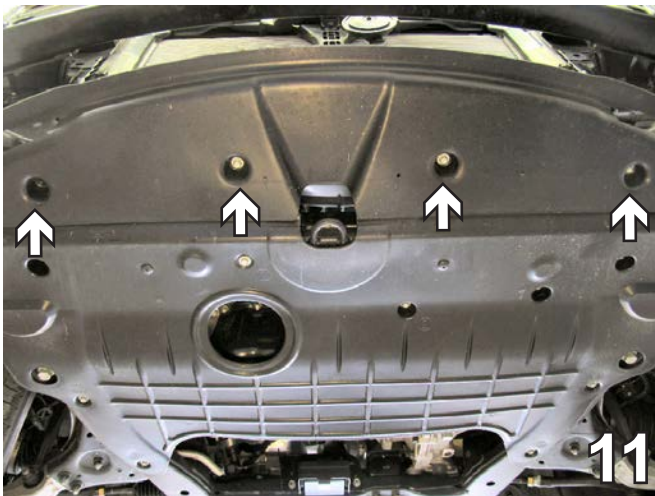

11. Using a 10MM socket, remove four bolts underneath the belly pan. Pull the belly pan forward and set aside to be reinstalled later.

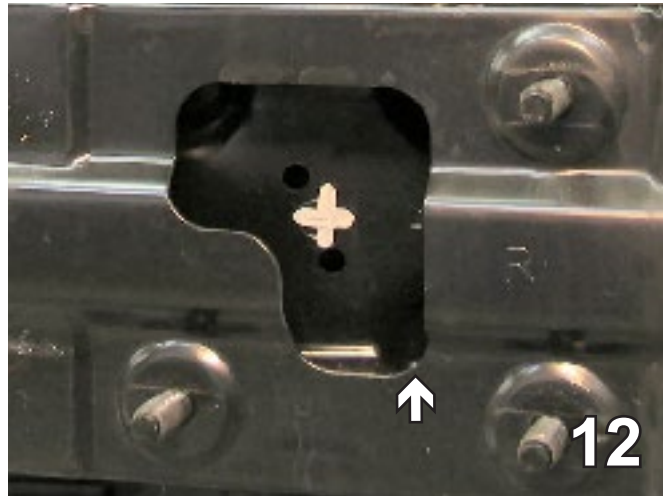

12. Using a 1 1/4" hole saw drill a 1 1/4" hole in the center of the metal bumper bracket opening. (It may be necessary to bend the bumper bracket to gain access.) Do this to both sides of the vehicle.

# BX2321

## 2006-10 Hyundai Sonata

### Installation Instructions



13. Remove two metric bolts from windshield washer reservoir using the 10MM socket. Unplug electrical connections, disconnect and plug water lines. Set washer reservoir and bolts aside to be reinstalled later.

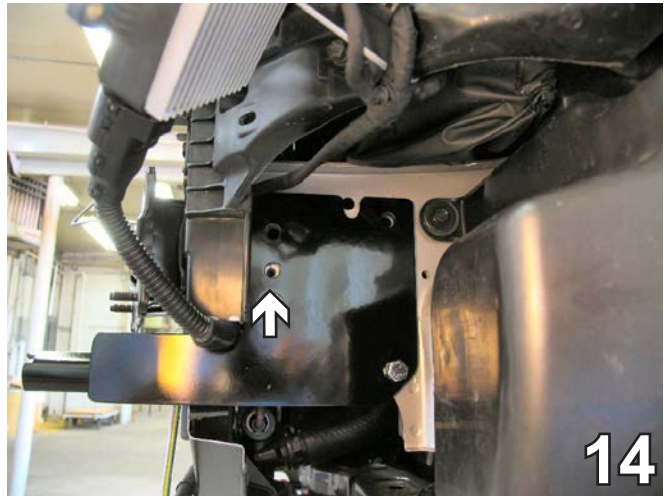

14. Using large vice grips, clamp the baseplate in place by aligning the front, center hole with the existing front hole for the fan controller on the driver's side (see white arrow in photo above). Insure the baseplate is level before clamping on the passenger's side.

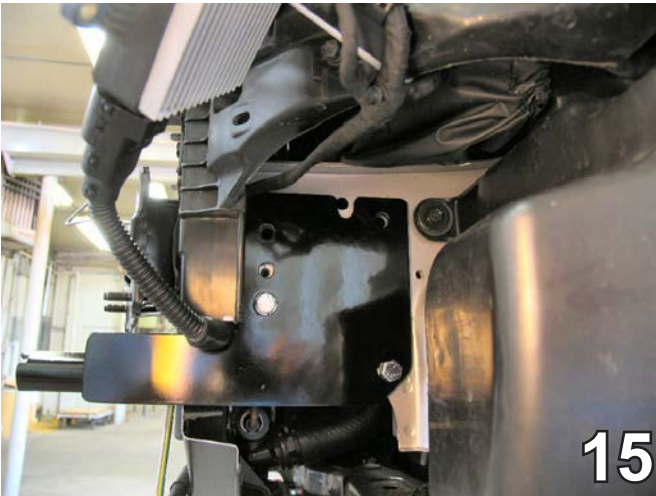

15. Using the baseplate as a template, drill five holes in the baseplate endplate with the 13/32" drill bit. Do this to both sides of the vehicle, the driver's side is shown.

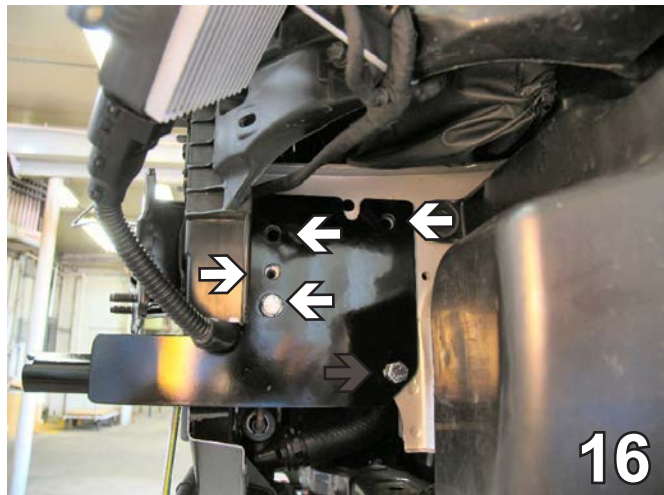

16. On driver's side, insert the 3/8-16 x 1 1/2" hex bolts and 3/8" lock washers into front and upper and lower holes and upper back hole, as indicated by the white arrows in the photo. Insert 3/8-16 x 1" hex bolt and 3/8" lock washer, 3/8" flat washer and 3/8" hex nut into the lower back hole, as shown by the grey arrow in the photo above. Tighten the lower bolt according to the torque specs on the front of these instructions or on page 3 of the Baseplate Towing General Instructions.

When using power drills be aware of the dangers of torque and drill bit length.

**\*\*BE SURE TO USE LOCTITE® RED ON ALL BOLTS BEFORE TIGHTENING. TIGHTEN ALL BOLTS ACCORDING TO THE TORQUE CHART ON THE FRONT PAGE OF THESE INSTRUCTIONS OR ON PAGE 3 OF THE BASEPLATE TOWING GENERAL INSTRUCTIONS.**



# BX2321

## 2006-10 Hyundai Sonata

### Installation Instructions

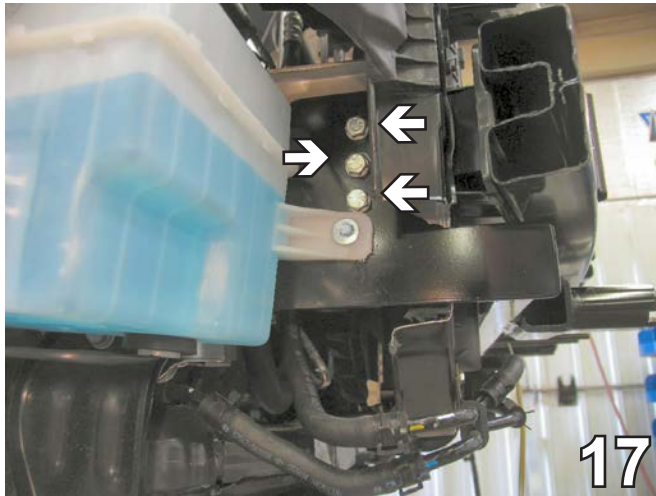

17. On passenger's side insert 3/8-16 x 1 1/2" hex bolt and 3/8" lock washer into 3 front holes, as indicated by the arrows in the photo above and upper back hole. Insert 3/8-16 x 1" hex bolt and 3/8" lock washer, 3/8" flat washer and 3/8" hex nut into lower back hole, located behind the washer reservoir in this photo.

**\*\*BE SURE TO USE LOCTITE® RED ON ALL BOLTS BEFORE TIGHTENING. TIGHTEN ALL BOLTS ACCORDING TO THE TORQUE CHART ON THE FRONT PAGE OF THESE INSTRUCTIONS OR ON PAGE 3 OF THE BASEPLATE TOWING GENERAL INSTRUCTIONS.**



19. Reinstall the fan controller to its original position using the 6MM-1.00 x 45MM hex bolt, 6MM lock washer and four 1/4" flat washers.

18. Insert nut plates into frame rail through hole in metal bumper bracket opening (drilled in Step 12) to align with 3/8 x 1/2" bolts and tighten. Tighten ALL bolts according to the torque specs on the first page of these instructions or on page 3 of the Baseplate Towing General Instructions.

**NOTE: There are three on the driver's side and four on the passenger's side.**



20. Slide windshield washer reservoir onto guide. Reinstall existing metric bolt on the back side, as indicated by the white arrow in the photo above. Insert 10-16 x 1" self drilling screw and 14" flat washer into the right side, as indicated by the grey arrow in the photo above. Reconnect electrical connections and water lines.

21. Reinstall the metal bumper to its original location see step 8 of these instructions.

**Be sure that ALL electrical connections are plugged in properly and functioning BEFORE installing the fascia.**

BX2321  
2006-10 Hyundai Sonata  
Installation Instructions



22. Reinstall horn to its original location. Be sure all electrical connections are plugged in properly.



23. Reinstall air dam and trim as needed to fit around the baseplate.

24. Reinstall fascia, inserting all screws, push pins and bolts.

25. Installation of baseplate is complete.

Install the tow bar and safety cables according to the instructions when demonstrating this to the customer,. Be sure to include all the contents and packages.

Do **NOT** substitute other devices if the tow bar pins and clips are misplaced.

# BX2321

## 2006-10 Hyundai Sonata

### Installation Instructions

#### **DEALER or INSTALLER:**

**Be certain the user receives the instruction sheets for their products.**



With removable tabs installed.



2008 with removable tabs installed.

If the baseplate is in an accident, it must be replaced. DO NOT use it again! An accident can cause unseen damage and using it again could result in more damage or serious injury. DO NOT use the baseplate if it is damaged or missing parts.

#### **CUSTOMER SERVICE COMMITMENT**

Blue Ox is committed to providing you with exceptional customer care throughout your lifetime with our products. Our team is here to assist you with any questions you may have regarding the performance of your product. Simply call (402) 385-3051 and you can speak with our customer care team.

Additionally, please visit our website to see which rallies our Destination America team will be attending. For a nominal fee, our service technician will service your towing system to ensure it's in proper working condition. Also as a commitment to our customers, should you visit our factory you can stay at our full service Blue Ox campground at no charge along with enjoying a factory tour.

Again thank you for being our customer and for the confidence you have shown in the performance of our products. It is because of customers like you we enjoy the success we have today.



© 2005, 07, 08, 10 Blue Ox  
One Mill Road, Industrial Park  
Pender, Nebraska 68047  
Phone: (402) 385-3051  
Fax: (402) 385-3360  
www.blueox.com

# General Information

1. Ensure that your product(s) are registered online at [www.blueox.com](http://www.blueox.com). It is crucial to register your product(s) so that you may be alerted of product offerings, updates, upgrades, maintenance and safety bulletins, and/or recalls.
2. **It is the owner's responsibility to inspect all towing equipment for cracked welds, missing or worn parts and loose bolts before each towing trip.** Be sure to use Loctite® Red on all bolts and tighten to the recommended specifications.
3. **It is the owner's responsibility to hook up all towing equipment per manufacturer's instructions/recommendations.**
4. Remove the attachment tabs when not in use (if applicable).

## Notice To Baseplate Installer

### 1. It is YOUR responsibility to watch for:

- Oil cooler and air conditioner lines
- Electrical wires and hoses
- Missing parts or attaching points on the frame

\*\* If the baseplate is improperly installed and is against a wire or hose, it could cause fluid leaks or electrical shorts some time after the actual baseplate installation.

## Permanent Baseplate Safety Cable Installation

Permanent baseplate safety cables are strongly recommended when towing a vehicle with a tow bar. The principle function of the permanent baseplate safety cables is to prevent the towed vehicle from breaking loose in the event the connection between the frame of the towed vehicle and the baseplate fails or becomes disconnected. The cables must be connected from the baseplate to the frame rail or cross member of the vehicle's frame. The illustrations below show the possible arrangements recommended by Blue Ox®. Each permanent baseplate safety cable must have an adequate weight rating for the towing system. The weight rating of the two (2) cables together will not qualify.

***Do not mount the permanent baseplate safety cables against wires, hoses or brake lines.***

These permanent baseplate safety cables should remain installed as long as the baseplate is installed on the vehicle. Permanent baseplate safety cables are to be used in conjunction with, and NOT a replacement for legally required safety cables attaching the towed vehicle to the towing vehicle.

### OPTION #1

Permanent Baseplate Safety Cables to Cross Member or Frame of Towed Vehicle.

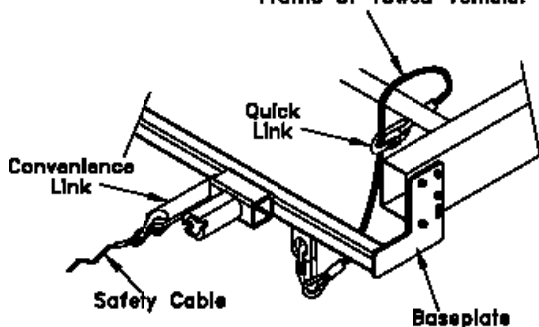

### OPTION #2

Permanent Baseplate Safety Cables to Cross Member or Frame of Towed Vehicle.

