



BX2621

**2010-12 Ford Flex Limited Ecoboost
Installation Instructions**

Attachment Tab Height: 24-1/4"

Attachment Tab Width: 24"

Serial Number

Please read BOTH these Installation Instructions and the General Information sheet prior to installing or operating this equipment.

- Blue Ox® towing products and accessories are intended to be installed by Blue Ox® Dealers who are familiar with our products and have the equipment and knowledge necessary to do "fit work". If needed, Blue Ox® Dealers can be found at www.blueox.com or by contacting our Technical Service Department at (402) 385-3051.
- Many Blue Ox® baseplates are designed to use existing holes and hardware to mount the baseplate to the towed vehicle. Even though bolts are there, do not assume they are adequate for baseplate mounting. Always use the hardware supplied in the hardware kit and existing hardware as specified in the installation instructions.

Bolt Torque Specifications

Torque in Foot-Pounds for Inch Bolts

Bolt Size	Grade 5	Grade 8
1/4"	10	14
5/16"	19	29
3/8"	33	47
7/16"	54	78
1/2"	78	119
5/8"	154	230
3/4"	257	380



If the front of your vehicle looks different than this, please contact us at (402)385-3051.

Reference your vehicle owner's manual for manufacturer's towing specifications.

Bolt Torque Specifications

Torque in Foot-Pounds for Metric Bolts

Bolt Size	Grade 8.8	Grade 10.9
6MM	6	8
8MM	16	22
10MM	31	40
12MM	54	70
14MM	89	117
16MM	161	230
18MM	222	318



WARNING

Failure to read and follow these instructions could result in separation of the towed vehicle from the tow bar, causing property damage, loss of towed vehicle, personal injury or death.



BX2621

2010-12 Ford Flex Limited Ecoboost Installation Instructions

- Tools Required**
- 10MM Socket
 - 12MM Socket
 - 7/16" Wrench
 - 9/16" Wrench
 - Large Vise Grip
 - Reciprocating Saw
 - Flat Screwdriver
 - Phillips Screwdriver
 - Utility Knife
 - Torque Wrench
 - Tape Measure
 - Drill
 - 1/4" Drill Bit
 - 13/32" Drill Bit
 - 1-1/4" Hole Saw
 - Loctite® Red

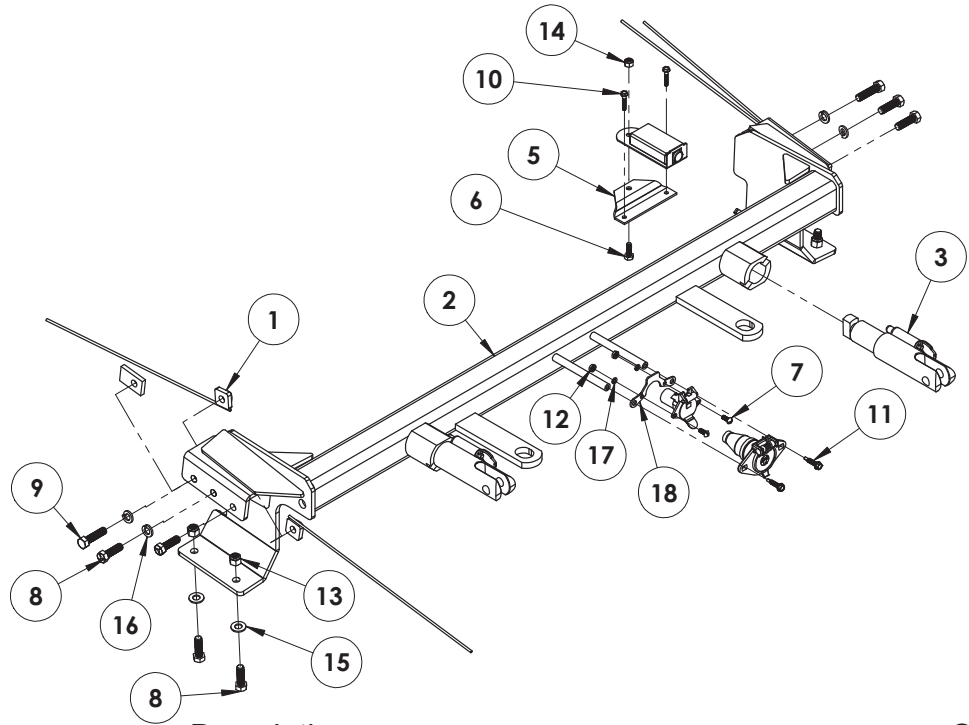

Item No.	Part No.	Description	Qty.
1.....	61-5208.....	3/8"-16 Nut Plate with 14" Wire.....	4
2.....	61-6762.....	BX2621 Baseplate.....	1
3.....	62-3468.....	Attachment Tab with Hole.....	2
4.....	102-7094.....	BX2621 Spacer.....	2
5.....	102-7249.....	BX2621 Breakaway Bracket.....	1
6.....	201-0050.....	1/4"-20 x 3/4" Hex Head Bolt, Grade 5, ZP.....	1
7.....	201-0192.....	#10-32 1/2" Round Slotted Head Screw.....	2
8.....	201-0368.....	3/8"-16 x 1-1/4" Hex Head Bolt, Grade 5, ZP.....	8
9.....	201-0440.....	3/8"-16 x 1-1/2" Hex Head Bolt, Grade 5, ZP.....	2
10.....	201-0654.....	#10-16 x 1" Self Tapping Screw, ZP.....	2
11.....	201-0979.....	#12-14 x 1" Self Drilling Screw, ZP.....	2
12.....	202-0047.....	#10-32 Hex Nut.....	2
13.....	202-0090.....	3/8"-16 Hex Nut with Nylon Insert, ZP.....	6
14.....	202-0102.....	1/4"-20 Hex Nut with Nylon Insert, ZP.....	1
15.....	203-0003.....	3/8" Flat Washer, ZP.....	6
16.....	203-0010.....	3/8" Lock Washer, ZP.....	4
17.....	203-0054.....	#10 Lock Washer.....	2
19.....	226-0049(not shown).....	36" Class IV Baseplate Safety Cables.....	2
20.....	229-0512(not shown).....	1/2" Quicklink, ZP.....	4
21.....	290-0437(not shown).....	Black Cap Plug.....	2

Important:

Use only genuine factory replacement parts on your baseplate. Do **NOT** substitute homemade or non-typical parts. If a bolt is lost or in need of replacement, for your safety and the preservation of your baseplate, be sure to use a replacement bolt of the same grade (In most cases it will be Grade 5, please reference the parts list above). Replacement parts may be ordered through your nearest Blue Ox® Dealer or Distributor. Failing to follow and/or altering these installation instructions in either installation or required equipment will void the manufacturer's warranty. Towing behind a non-motorized vehicle will void the warranty.



BX2621

2010-12 Ford Flex Limited Ecoboost Installation Instructions

Attachment Tabs: Due to the design of the removable tabs, the RangeFinderII tow bar can not be used. Adapters, except the BX8833 and BX88151, can not be used with this baseplate.

Installation Notes: The front fascia and metal bumper are removed during installation. Drilling is required. Trimming is required.

The dimensional variations between otherwise identical vehicles can be considerable. While the baseplate was designed for easy installation, it may be necessary to tailor the baseplate slightly to compensate for auto manufacturer's tolerances. These minor adjustments may include filing a hole slightly, bending electrical rods or bending end plates.

The BX8848 4-Diode Wiring Kit is recommended for this vehicle.

Handling of some cosmetic parts when installing this product may require the use of protective covers, rags, specialty tools, etc. to prevent damage.

Do not use the towed vehicle for storing luggage, equipment, etc. This may cause you to exceed the towing capacity of the tow bar, baseplate, and its accessories.

Installation Instructions:



1. Using the 10MM socket, remove the metric bolt from the top corner of the grille (white arrow). Remove two pushpins from the top of the grille (gray arrows). Do this to both sides of the vehicle. Set bolts and pushpins aside to be reinstalled later.



2. Just forward of the front tire, inside the wheel well, using 5.5MM socket remove three screws. Do this to both sides of the vehicle. Set screws aside to be reinstalled later.



2010-12 Ford Flex Limited Ecoboost Installation Instructions

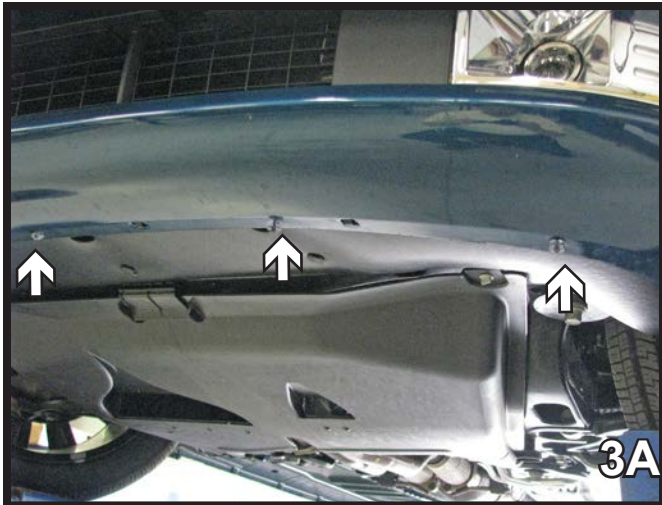

3. Using the 5.5MM socket, remove the seven bolts from the bottom edge of the fascia. Set bolts aside to be reinstalled later.

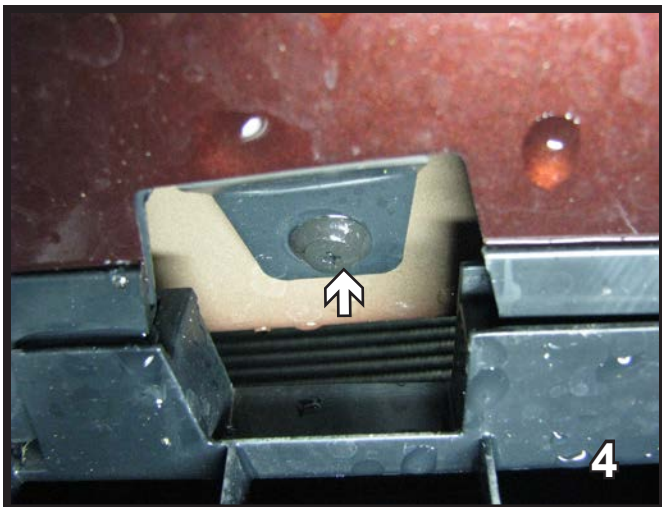

4. Using the Phillips screwdriver, remove two pushpins located underneath the fascia to each side of the license plate bracket. Pull fascia forward to remove. Set fascia and pushpins aside carefully to be reinstalled later.

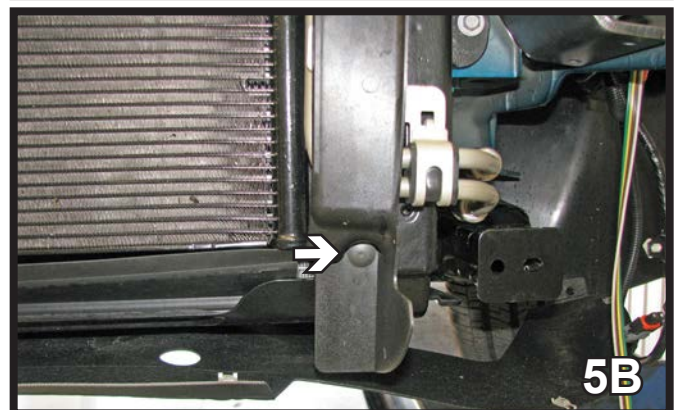
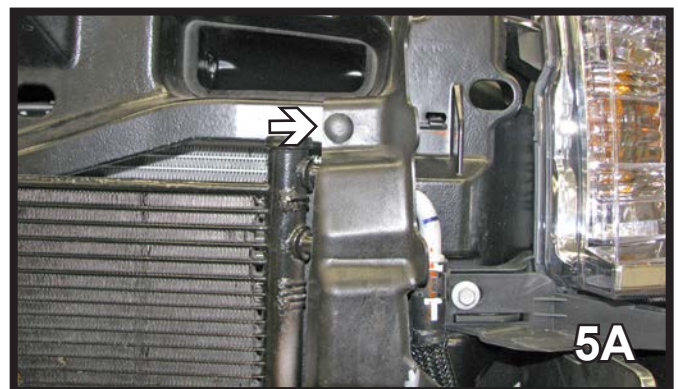

5. Remove two pushpins, one on top (5A) and one on the bottom (5B) holding the plastic guard above the bumper. Do this to both sides of the vehicle. Set guard and pushpins aside to be reinstalled later.



6. On vehicles equipped with a temperature sensor, the sensor will be relocated from the top of the bumper to the bottom. Unclip sensor from the top of the bumper and move aside.



2010-12 Ford Flex Limited Ecoboost Installation Instructions

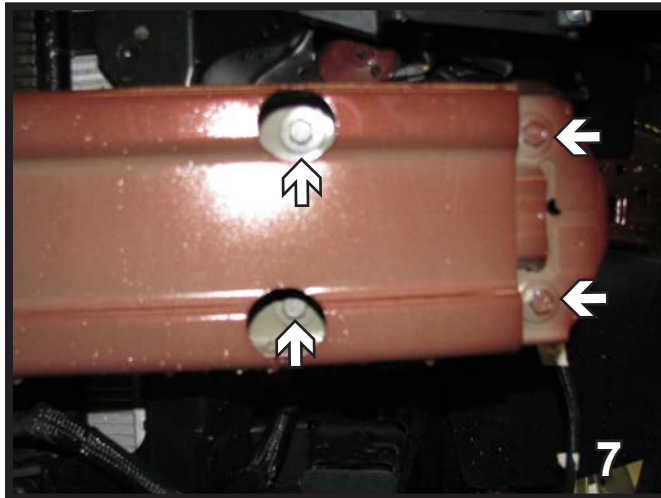

7. Using the 13MM socket, remove four metric bolts from the bumper, two on each side. Set the bolts aside to be reinstalled later.

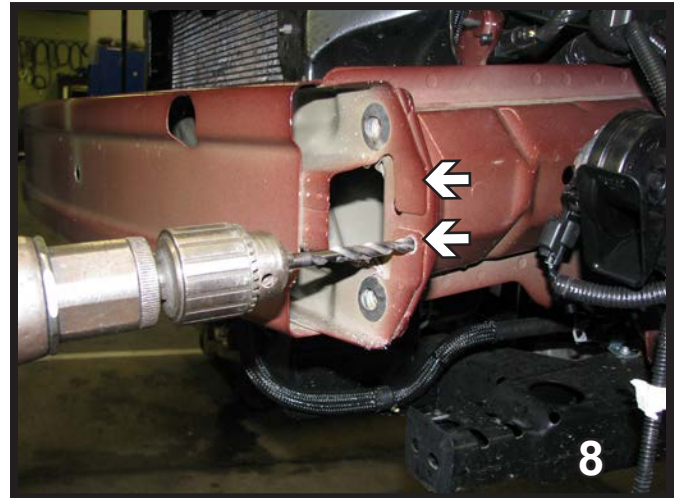

8. Using the 1/4" drill bit, drill out the two spot welds on each side. Remove the bumper and set aside to be reinstalled later.

When using power drills be aware of the dangers of torque and drill bit length.

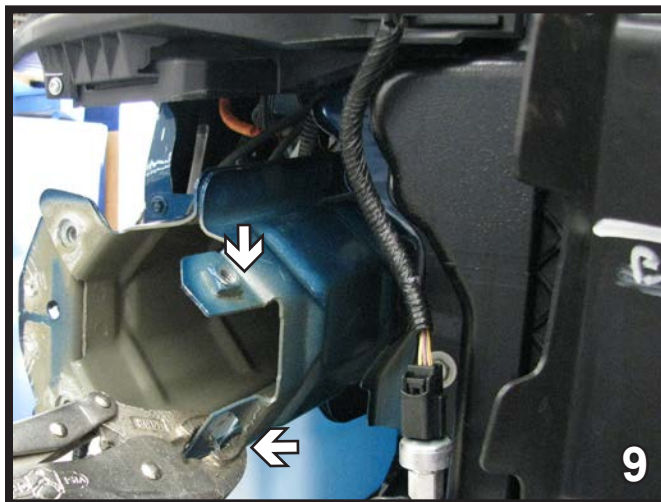

9. On the frame rail, using the vise grip, bend the two inside tabs out flat with the frame. On top of the frame rail, bend the center ribbing toward the radiator (about 6" back from the end). Do this to both sides of the vehicle.

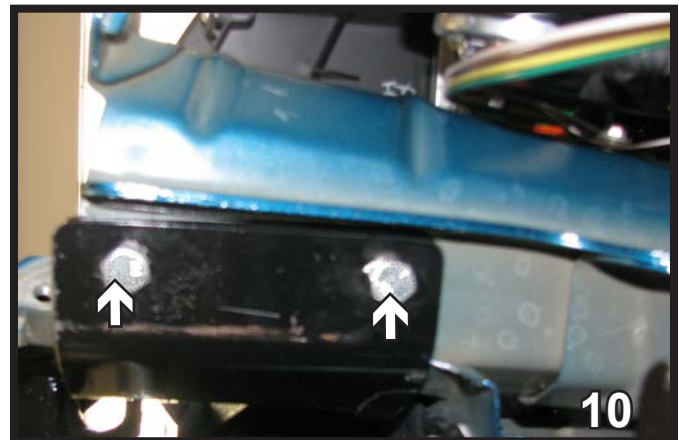

10. Slide the baseplate up on the frame rail. Insure the baseplate is level with respect to the vehicle frame. Using the baseplate as a template, drill the two holes on the bottom of the baseplate (10) and the three holes on the side of the baseplate (11) with the 13/32" drill bit. On the bottom (as shown in picture 10) use 3/8-16 x 1" bolts with 3/8" flat washers and 3/8-16 lock nuts. Use Loctite on all bolts. Do this to both sides of the vehicle.

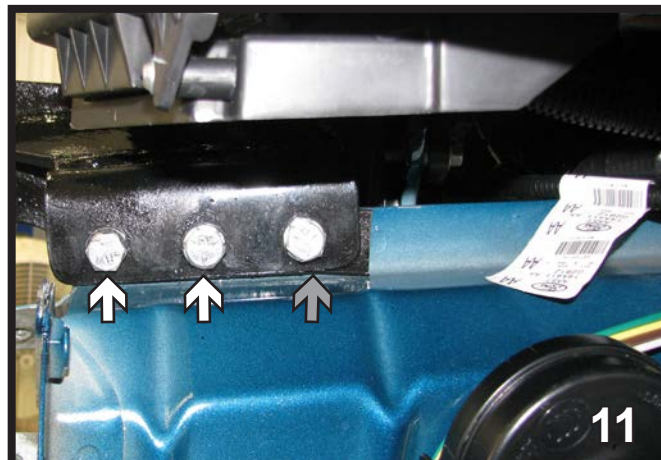

11. Attach 3/8 x 1" bolt to 3/8" flat washer and 3/8-16 lock nut in the front hole. In the middle hole, insert a 3/8-16 x 1 1/4" bolt with 3/8" lock washer and 3/8-16 nut plate. In the hole closest to the vehicle (gray arrow), use 3/8-16 x 1 1/2" bolt and 3/8" lock washer with a spacer behind the baseplate and a 3/8" nut plate. Use Loctite Red on all bolts. Do this to both sides of the vehicle.



BE SURE TO USE LOCTITE® RED ON ALL BOLTS BEFORE TIGHTENING. TIGHTEN ALL BOLTS ACCORDING TO THE TORQUE CHART ON THE FRONT PAGE OF THESE INSTRUCTIONS OR ON PAGE 3 OF THE BASEPLATE TOWING GENERAL INSTRUCTIONS.

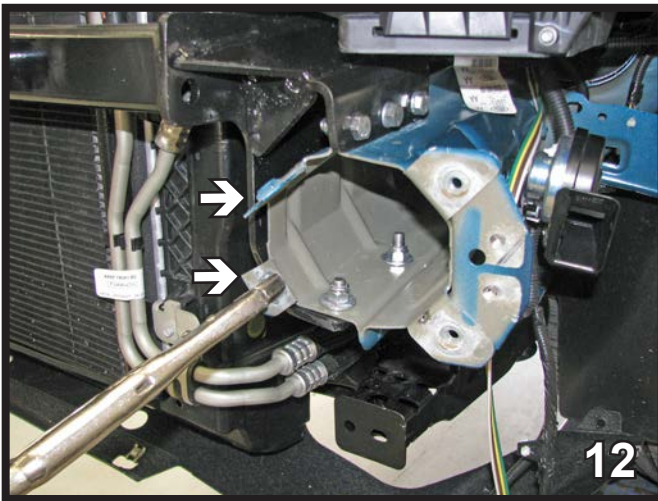

12. Using a vise grip, bend the two tabs back. Do this to both sides of the vehicle. Reinstall the bumper.



13. After bumper is reinstalled, when applicable, relocate temperature sensor on passenger's side to the bottom of the bumper using existing holes.

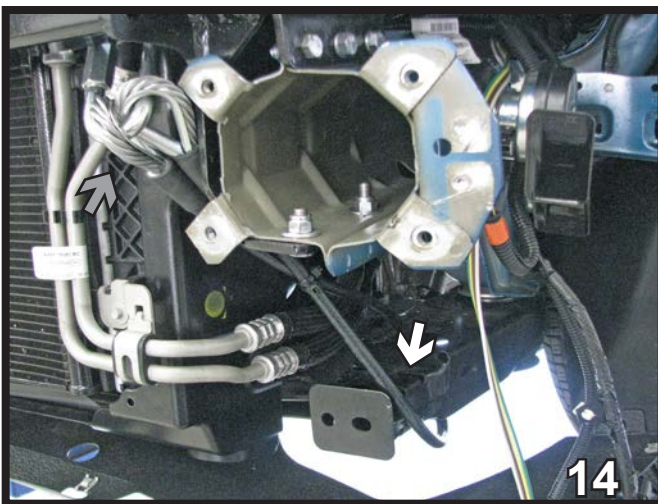

14. Attach the permanent baseplate safety cables to the provided convenience link on the baseplate (gray arrow). The photo above shows the recommended installation of the permanent baseplate safety cables to frame of the vehicle (white arrow). If the vehicle has additional options, not shown above, which interfere with mounting the permanent baseplate safety cables, secure the cable to a solid piece of the vehicle's frame as described in the instructions included with the permanent baseplate safety cables. Do this to both sides of the vehicle.

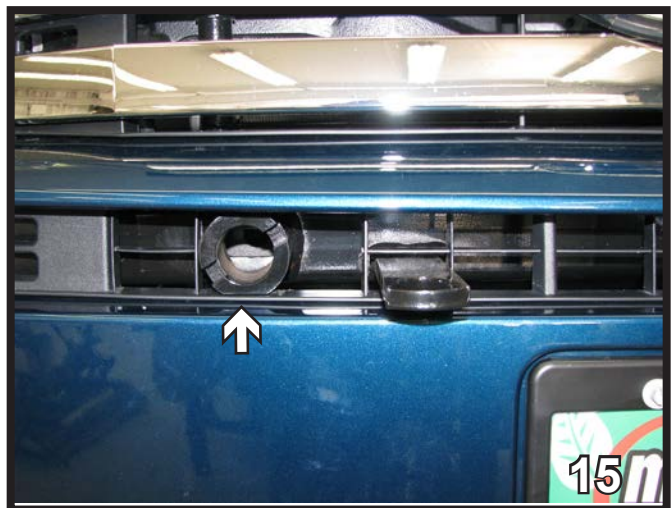

15. Before installing the electrical plug, hold the fascia up in its original location, cut out the horizontal piece from the fascia with the hacksaw blade as necessary for the attachment tabs to come through. Do this to both sides of the vehicle.

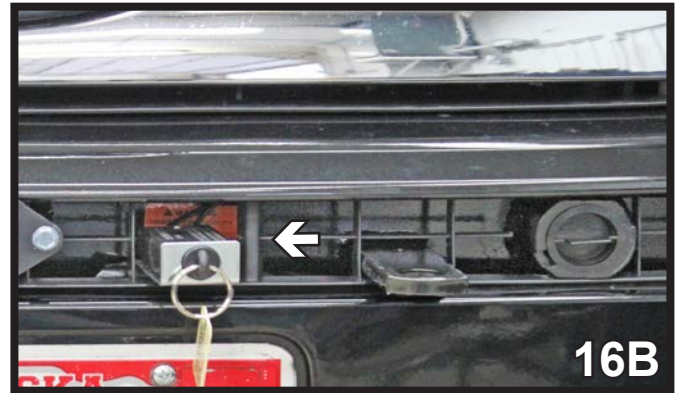
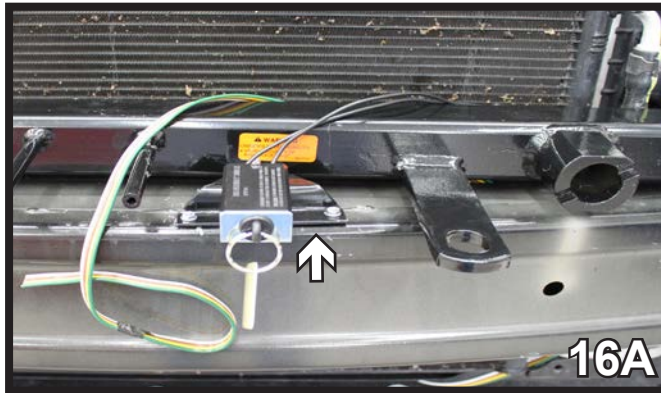

16. OPTIONAL: Attach breakaway bracket to metal bumper using #10-16 x 1 1/2 self-drilling screws (16A). The metal bumper may require a pilot hole be drilled prior to attaching the breakaway bracket.

After attaching the breakaway bracket, while holding up the fascia to its original location, cut out an additional horizontal piece from the fascia with the hacksaw blade to accommodate the breakaway as shown in picture 16B. Reinstall fascia.



17. Install the electrical plug on the front of the fascia.

Install the tow bar and safety cables according to the instructions provided in their packages. When demonstrating this to the customer, be sure to include all the contents and packages.

Do **NOT** substitute other devices if the tow bar pins and clips are misplaced.

DEALER or INSTALLER:
Be certain the user receives the instruction sheets for their products.

Be sure that **ALL** electrical connections are plugged in properly and functioning **BEFORE** installing the fascia.

If the baseplate is in an accident, it must be replaced. DO NOT use it again! An accident can cause unseen damage and using it again could result in more damage or serious injury. DO NOT use the baseplate if it is damaged or missing parts.



BLUE OX®

BX2621

2010-12 Ford Flex Limited Ecoboost Installation Instructions



2011 - Shown without removable tabs installed.



2011 - Shown with removable tabs installed.

CUSTOMER SERVICE COMMITMENT

Blue Ox® is committed to providing you with exceptional customer care throughout your lifetime with our products. Our team is here to assist you with any questions you may have regarding the performance of your product. Simply call (402) 385-3051 and you can speak with our technical service team.

Additionally, please visit our website to see which rallies our Destination America team will be attending. For a nominal fee, our service technician will service your towing system to ensure it's in proper working condition. Also, as a commitment to our customers, should you visit our factory, you can stay at our full service Blue Ox® campground at no charge along with enjoying a factory tour.

Again, thank you for being our customer and for the confidence you have shown in the performance of our products. It is because of customers like you we enjoy the success we have today.

© 2016 Blue Ox
One Mill Road, Industrial Park
Pender, Nebraska 68047
Phone: (402) 385-3051
Fax: (402) 385-3360
www.blueox.com

General Information

1. Ensure that your product(s) are registered online at www.blueox.com. It is crucial to register your product(s) so that you may be alerted of product offerings, updates, upgrades, maintenance and safety bulletins, and/or recalls.
2. **It is the owner's responsibility to inspect all towing equipment for cracked welds, missing or worn parts and loose bolts before each towing trip.** Be sure to use Loctite® Red on all bolts and tighten to the recommended specifications.
3. **It is the owner's responsibility to hook up all towing equipment per manufacturer's instructions/recommendations.**
4. Remove the attachment tabs when not in use (if applicable).

Notice To Baseplate Installer

1. It is YOUR responsibility to watch for:

- Oil cooler and air conditioner lines
- Electrical wires and hoses
- Missing parts or attaching points on the frame

** If the baseplate is improperly installed and is against a wire or hose, it could cause fluid leaks or electrical shorts some time after the actual baseplate installation.

Permanent Baseplate Safety Cable Installation

Permanent baseplate safety cables are strongly recommended when towing a vehicle with a tow bar. The principle function of the permanent baseplate safety cables is to prevent the towed vehicle from breaking loose in the event the connection between the frame of the towed vehicle and the baseplate fails or becomes disconnected. The cables must be connected from the baseplate to the frame rail or cross member of the vehicle's frame. The illustrations below show the possible arrangements recommended by Blue Ox®. Each permanent baseplate safety cable must have an adequate weight rating for the towing system. The weight rating of the two (2) cables together will not qualify.

Do not mount the permanent baseplate safety cables against wires, hoses or brake lines.

These permanent baseplate safety cables should remain installed as long as the baseplate is installed on the vehicle. Permanent baseplate safety cables are to be used in conjunction with, and NOT a replacement for legally required safety cables attaching the towed vehicle to the towing vehicle.

Option #1

(Baseplates with Convenience Link Tabs)

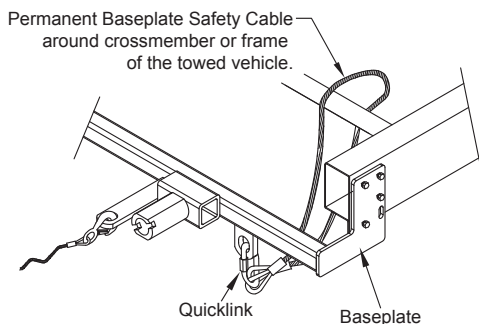

Option #2

(Baseplates with out Convenience Link Tabs)

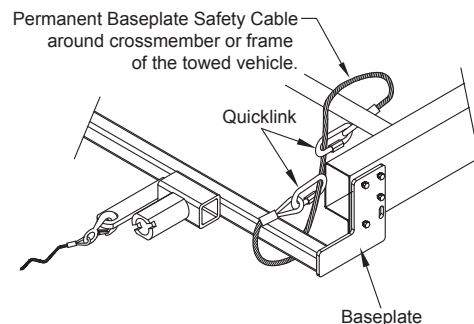

BLUE OX ORIGINAL PURCHASERS THREE YEAR LIMITED WARRANTY

Automatic Equipment Manufacturing Company ("Automatic") warrants to the original (first) retail purchaser that this product, manufactured by Automatic, shall be free from defect in material and workmanship under normal use and service for a period of three years from the date of delivery.

During said three-year period, Automatic will repair or replace any parts that have been returned by the original purchaser, to the factory, transportation prepaid, and in Automatic's sole and absolute opinion found to be defective.

Limitations on Warranty Coverage:

Coverage under this warranty will be valid only if the customer warranty card is returned by the original purchaser within 30 days of purchase.

Coverage under this warranty will be effective only when a copy of the original invoice, showing date and place of purchase, accompanies any claim for warranty. This warranty is NON TRANSFERABLE.

This limited warranty will not cover, in any way or form, any alleged damages caused by incorrect or improper installation, improper use, modification or neglect of product, failure to properly service and maintain, misuse, act of God, accident or failure of the user to follow guidelines contained in the instructional material provided by Automatic.

This warranty does not cover normal wear and tear, paint or rust.

Warrantor assumes no responsibility to the owner for loss of use of product, loss of time, inconvenience or any other damage consequential or otherwise. Including, but not limited to mileage, expense of transporting of product, return shipping expense, mechanics travel time, telephone, road service, towing, and rental during repairs, travel, lodging, loss or damage to personal property or loss of earnings.

REPAIR OR REPLACEMENT AS SET FORTH IN THIS LIMITED WARRANTY IS THE SOLE EXCLUSIVE REMEDY OF THE PURCHASER. AUTOMATIC SHALL NOT BE LIABLE FOR ANY INCIDENTAL OR CONSEQUENTIAL DAMAGES FOR BREACH OF ANY EXPRESS OR IMPLIED WARRANTY ON THIS PRODUCT. EXCEPT TO THE EXTENT PROHIBITED BY APPLICABLE LAW, ANY IMPLIED WARRANTY OF MERCHANTABILITY OR FITNESS FOR A PARTICULAR PURPOSE ON THIS PRODUCT IS LIMITED IN LENGTH TO THE DURATION OF THIS WARRANTY.

Please visit <http://blueox.com/warranty/> to register your warranty

