

BLUE OX® Baseplates

2003-05 Saturn L Series Installation Instructions

Serial Number

Please read BOTH these Installation Instructions and the General Instructions before attempting to install or operate this equipment.

1. Blue Ox® towing products and accessories are intended to be installed by Blue Ox® Dealers who are familiar with our products and have the equipment necessary and knowledge to do “fit work”. When necessary Blue Ox® Dealers can be found at www.blueox.us or by contacting our 24/7 Customer Care Department at (402) 385-3051 or toll free at (888) 425-5382.
2. Many Blue Ox® Baseplates are designed to use existing holes and hardware to mount the baseplate to the towed vehicle. Even though bolts are there, do not assume they are adequate for baseplate mounting. Always use hardware supplied in the hardware kit and existing hardware specified in the Baseplate Installation Instructions.

Attachment Tab Height: 14”
Attachment Tab Width: 24”

Bolt Torque Specifications
Torque in Foot-Pounds per Metric Bolts

Bolt Size	Grade 8.8	Grade 10.9
6MM	6	8
8MM	16	22
10MM	31	40
12MM	54	70
14MM	89	117

Confirm the towability and pre-towing procedures for your vehicle with the owner’s manual or contact the vehicle’s manufacturer for specific towing procedures. You can also contact REMCO for additional information at 1(800)228-2481.

Bolt Torque Specifications
Torque in Foot-Pounds per Inch Bolts

Bolt Size	Grade 5	Grade 8
1/4”	10	14
5/16”	19	29
3/8”	33	47
7/16”	54	78
1/2”	78	119
5/8”	154	230



! WARNING

Failure to read and follow these instructions could result in separation of the towed vehicle from the tow bar, causing property damage, loss of towed vehicle, personal injury or death.

BX3323

2003-05 Saturn L Series

Installation Instructions

Parts List

Ref. No.	Qty.	Part #	Description
1	1	61-6059	Weldment, Baseplate, BX3323
2	2	102-6314	Support Brace
3	8	61-5208	3/8-16 Nut Plate
4	2	62-3468	Attachment ,Assembly ,F/SB (R)
5	2	201-0443	3/8--16 x 1" Bolt, Grd 5, ZP
6	8	201-0440	3/8-16 x 1 1/2" Bolt, Grd. 5, ZP
7	2	203-0003	3/8" Flat Washer, ZP
8	10	203-0010	3/8 Lock Washer, ZP
9	2	202-0003	3/8-16 Hex Nut, ZP
10	2	201-0979	#12-14 x 1" Self Drilling Screw, ZP
11	2	101-5822	Adapter, 4 Way Connector
12	2	201-0192	#10-32 x 1/2" Slot, Rd. Hd. Screw
13	2	203-0054	#10 Lock Washer
14	2	202-0047	#10-32 Hex Nut
15	2	290-0437	Cap Plug, Blac k, (Not Shown)

Tools Required

- 7MM Wrench
- 13MM Socket
- 9/16" Socket
- 3/4" Socket
- 9/32" Socket
- 13/32" Drill Bit
- Large Vise Grip
- Loctite® RED

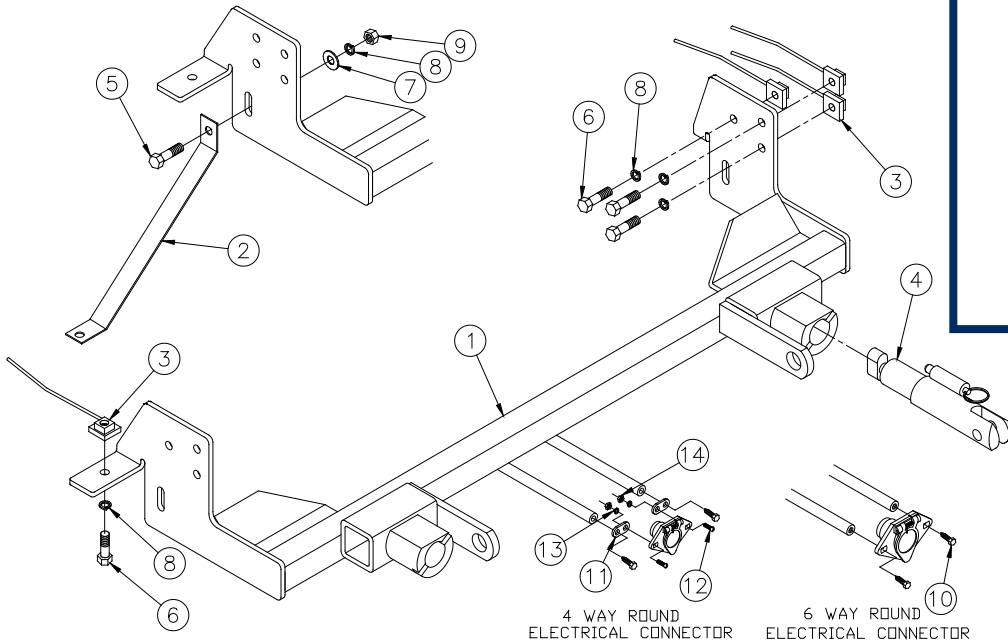

Important:

Use only genuine factory replacement parts on your baseplate. Do NOT substitute homemade or non-typical parts. If a bolt is lost or in need of replacement, for your safety and the preservation of your baseplate, be sure to use a replacement bolt of the same grade (In most cases it will be Grade 5, please reference the parts list above). Replacement parts may be ordered through your nearest Blue Ox® Dealer or Distributor, or call our 24/7 Customer Care Team at (402)385-3051.

BX3323

2003-05 Saturn L Series Installation Instructions

Removable Tabs:

Due to the design of the removable tabs, the RangeFinder II tow bar can not be used. Adapters, except for the BX8833 and the BX88151 can not be used with this baseplate.

Installation Notes:

The front fascia brace and metal bumper are removed and reinstalled for the baseplate installation. Drilling is required. Some vehicle's fascia's may need trimming.

The dimensional variations between otherwise identical vehicles can be considerable. While the baseplate was designed for easy installation, it may be necessary to tailor the baseplate slightly to compensate for auto manufacturer's tolerances. These minor adjustments may include filing a hole slightly, bending electrical rods, and/ or bending end plates.

The BX8869 Bulb and Socket Wiring Kit is recommended for this vehicle.

Installation Instructions:



1. Remove three pushpins from the top side of the grille. Set the pushpins and the grille aside to be reinstalled later.



2. Just forward of the front tires, in the wheel well, remove four pushpins. Set the pushpins aside to be reinstalled later. Do this to both sides of the vehicle.



3. Remove one pushpin from the fascia support. Using the 10MM socket, remove one metric bolt. Set the metric bolt aside to be reinstalled later. The factory fascia support will not be reinstalled.

BX3323
2003-05 Saturn L Series
Installation Instructions

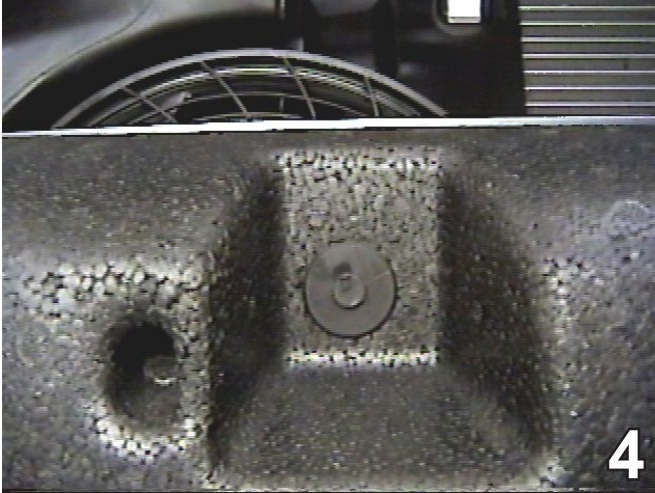

4. Just forward of the wheel well, behind the fascia's upper corner, push clip up to unlock the fascia. Do this to both sides of the vehicle. Fascia will unlock properly when you hear a click, pull the fascia forward and set it aside to be reinstalled later. Remove three pushpins from the Styrofoam insert. Pull the Styrofoam bumper forward. Set the pushpins and the Styrofoam bumper aside to be reinstalled later.



5. Using the 13MM socket, remove six metric bolts from the metal bumper. Pull it forward and set it aside to be reinstalled later.

NOTICE: Pull the air baffle tube straight down on the passenger's side to release and expose inner frame area. Set the tube aside to be reinstalled later.



6. Bend the upper fascia support bracket forward 90 degrees. Do this to both sides of the vehicle.

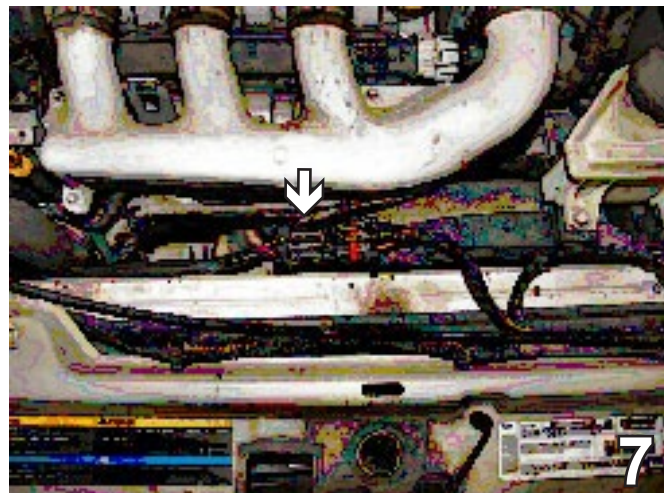

7. Pull the electrical coupler on the top of the radiator toward the driver's side to release from the bracket and unplug.

BX3323
2003-05 Saturn L Series
Installation Instructions



8. Using a 10MM socket to remove one metric bolt from radiator bracket . Set the bolt and the radiator aside to be reinstalled later.



9. Using the 10MM socket, remove the two metric bolts from the lower fan assembly, pull the fan assembly down to remove from the radiator and set all aside to be reinstalled later.

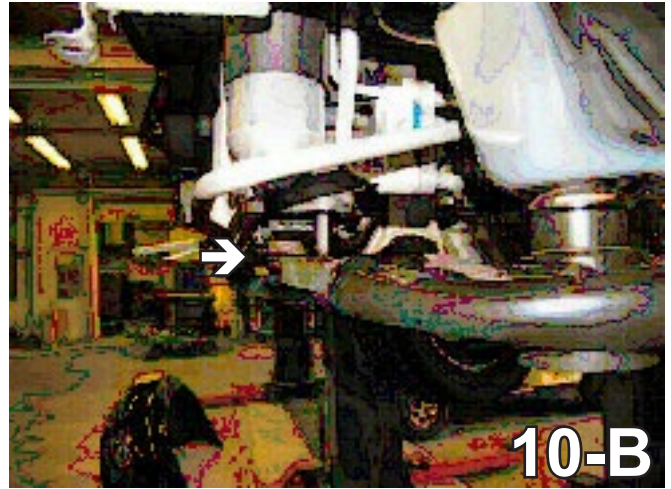
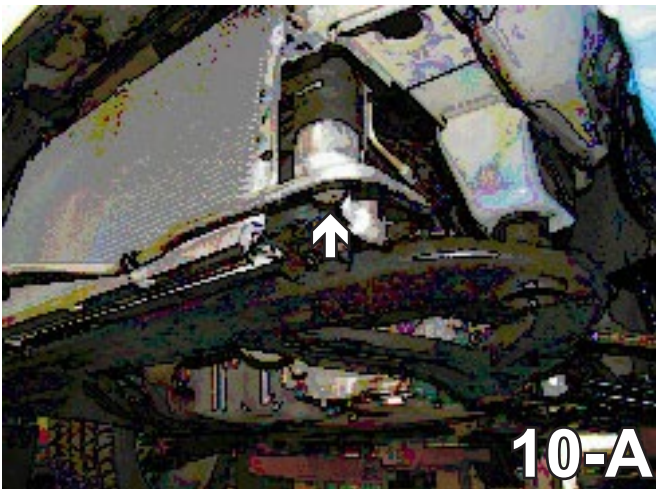

10. Lift the radiator assembly alignment pin up and out of the rubber grommet and push the assembly back toward the engine. This will open the frame area to allow proper installation of baseplate.

BX3323
2003-05 Saturn L Series
Installation Instructions



11. Clamp the baseplate to the bottom of the frame with the vise grips (11-A). The top edge of the baseplate will align with the top of the frame end and as far forward as possible while maintaining a level position with the vehicle. Set fascia in place on the vehicle, slide the attachment tabs through the upper grill openings as shown in 11-B. Some vehicles may require trimming of area just above the attachment tabs to prevent fascia from bending too much. Trimming should be done after baseplate is installed completely.

BE SURE TO USE LOCTITE® RED ON ALL BOLTS BEFORE TIGHTENING. TIGHTEN ALL BOLTS ACCORDING TO THE TORQUE CHART ON THE FRONT PAGE OF THESE INSTRUCTIONS OR ON PAGE 3 OF THE BASEPLATE TOWING GENERAL INSTRUCTIONS.

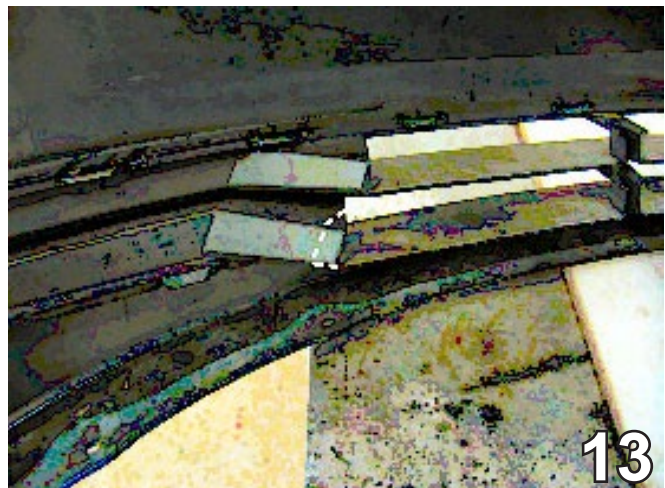

12. Using the baseplate as a template, drill the lower hole into the bottom of the frame rail. Do this to both sides of the vehicle. When drilling holes into the bottom of the frame, be aware of the coolant line on the passenger's side. Insert nut plate into the hole on the bottom side of frame to align with the drilled holes tighten the 3/8-16 hex bolts and lock washers on both sides according to the drawing on page 2.

13. Using the baseplate as a template, drill the lower hole into the bottom of the frame rail. Do this to both sides of the vehicle. When drilling the holes into the bottom of the frame, be aware of the coolant line on the passenger's side. Insert the nut plate into the hole on the bottom side of the frame to align with the drilled holes. Tighten the 3/8-16 hex bolts and lock washers. Do this to both sides of the vehicle. Reference the drawing on page 2.

BX3323

2003-05 Saturn L Series Installation Instructions



14. Reinstall the air baffle tube on the passenger's side, metal bumper, Styrofoam and fascia. Replace fascia brace with the support brace, 3/8-16 x1" hex bolt, flat washer and lock washer, and attach it to the baseplate as shown on page 2. Attach the other end to the fascia mount with existing pushpin, some trimming of the fascia may be required as shown in Step 11. **DO NOT CUT THE HORIZONTAL RIB OF THE FASCIA.**

Be sure that ALL electrical connections are plugged in properly and functioning BEFORE installing the fascia.

Install the tow bar and safety cables according to the instructions provided in their packages. When demonstrating this to the customer, be sure to include all the contents and packages.

Do **NOT** substitute other devices if the tow bar pins and clips are misplaced.



**The location for the BX8869
Bulb and Socket Kit.**

DEALER or INSTALLER:

Be certain the user receives the instruction sheets for their products.

Customer Service Commitment

Blue Ox® is focused on providing exemplary customer service, as observed in our mission statement and guiding principles. In accordance with this objective, Blue Ox® is proud to provide services such as repairs and general maintenance of Blue Ox® products at over 150 RV Rallies. Look for our Destination America or Blue Ox® Racing service crews at the next rally or NASCAR race that you attend. If you were not present, you will find an informative, personalized note explaining any services that may have been performed to your Blue Ox® products.

Blue Ox® also offers educational seminars at rallies and through our Parks and Resort teams. In addition, Blue Ox® customers visiting our factory may take advantage of the well-equipped Blue Ox® RV park at no charge to you, our valued and appreciated customer.



© 2006 Blue Ox
One Mill Road, Industrial Park
Pender, Nebraska 68047
Phone: (402) 385-3051
Toll Free: (888) 425-5382
Fax: (402) 385-3360
www.blueox.us
292-6045
Page 7 of 7

General Information

1. Ensure that your product(s) are registered online at www.blueox.com. It is crucial to register your product(s) so that you may be alerted of product offerings, updates, upgrades, maintenance and safety bulletins, and/or recalls.
2. **It is the owner's responsibility to inspect all towing equipment for cracked welds, missing or worn parts and loose bolts before each towing trip.** Be sure to use Loctite® Red on all bolts and tighten to the recommended specifications.
3. **It is the owner's responsibility to hook up all towing equipment per manufacturer's instructions/recommendations.**
4. Remove the attachment tabs when not in use (if applicable).

Notice To Baseplate Installer

1. It is YOUR responsibility to watch for:

- Oil cooler and air conditioner lines
- Electrical wires and hoses
- Missing parts or attaching points on the frame

** If the baseplate is improperly installed and is against a wire or hose, it could cause fluid leaks or electrical shorts some time after the actual baseplate installation.

Permanent Baseplate Safety Cable Installation

Permanent baseplate safety cables are strongly recommended when towing a vehicle with a tow bar. The principle function of the permanent baseplate safety cables is to prevent the towed vehicle from breaking loose in the event the connection between the frame of the towed vehicle and the baseplate fails or becomes disconnected. The cables must be connected from the baseplate to the frame rail or cross member of the vehicle's frame. The illustrations below show the possible arrangements recommended by Blue Ox®. Each permanent baseplate safety cable must have an adequate weight rating for the towing system. The weight rating of the two (2) cables together will not qualify.

Do not mount the permanent baseplate safety cables against wires, hoses or brake lines.

These permanent baseplate safety cables should remain installed as long as the baseplate is installed on the vehicle. Permanent baseplate safety cables are to be used in conjunction with, and NOT a replacement for legally required safety cables attaching the towed vehicle to the towing vehicle.

OPTION #1

Permanent Baseplate Safety Cables to Cross Member or Frame of Towed Vehicle.

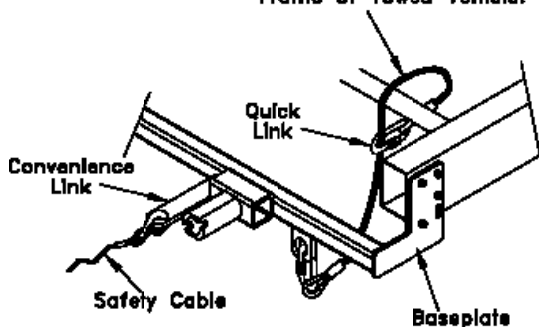

OPTION #2

Permanent Baseplate Safety Cables to Cross Member or Frame of Towed Vehicle.

