

Please read BOTH these Installation Instructions and the General Instructions before attempting to install or operate this equipment.

- Blue Ox® towing products and accessories are intended to be installed by Blue Ox® Dealers who are familiar with our products and have the equipment necessary and knowledge to do "fit work". When necessary Blue Ox® Dealers can be found at www.blueox.com or by contacting our Customer Care Department at (402) 385-3051.
- Many Blue Ox® Baseplates are designed to use existing holes and hardware to mount the baseplate to the towed vehicle. Even though bolts are there, do not assume they are adequate for baseplate mounting. Always use hardware supplied in the hardware kit and existing hardware specified in the Baseplate Installation Instructions.

Attachment Tab Height: 15"

Attachment Tab Width: 21"

Bolt Torque Specifications

Torque in Foot-Pounds for Metric Bolts

Bolt Size	Grade 8.8	Grade 10.9
6MM	6	8
8MM	16	22
10MM	31	40
12MM	54	70
14MM	89	117

Confirm the and pre-towing procedures for your vehicle with the owner's manual or contact the vehicle's manufacturer for specific towing procedures.

Bolt Torque Specifications

Torque in Foot-Pounds for Inch Bolts

Bolt Size	Grade 5	Grade 8
1/4"	10	14
5/16"	19	29
3/8"	33	47
7/16"	54	78
1/2"	78	119
5/8"	154	230



If the front of your vehicle looks different than this, call us at (402) 385-3051.

! WARNING

Failure to read and follow these instructions could result in separation of the towed vehicle from the tow bar, causing property damage, loss of towed vehicle, personal injury or death.

BX3828 2008 VW EOS Installation Instructions

Parts List

Ref. No.	Qty.	Part #	Description
1	1	61-6543	WLDM'T, BP, BX3828
2	1	101-7245	INNER SUPPORT, DS, BX3828
3	1	101-7246	INNER SUPPORT, PS, BX3828
4	6	102-5484	NUT PLATE, 1/4 X 1 X 1"(.531)
5	2	203-0005	1/2 FLAT WASHER, ZP
6	6	61-5208	WLD, NUT PLT, 1/4X1X1, 3/8"/14"WIRE
7	2	61-3799	WELDMENT, NUT PLATE, BX3301
8	8	201-0368	3/8-16 X 1 1/4 HEX HEAD BOLT,GRD. 5
9	6	201-0440	3/8-16 X 1 1/2 HEX BOLT, GRD.5, ZP
10	2	201-0051	1/2-13 X 1 1/2 HEX BOLT GRD.5, ZP
11	14	203-0010	3/8 LOCK WASHER, ZP
12	2	203-0012	1/2 LOCK WASHER, ZP
13	8	202-0071	3/8-16 HEX FLANGE WHIZ LOCK NUT, ZP
14	2	201-0979	#12-14 X 1" SELF DRILLING SCREW, ZP
15	2	201-0192	10-32 X 1/2 SLOT, RD. HD. SCREW
16	2	203-0054	#10 LOCK WASHER
17	2	202-0047	#10-32 HEX NUT
18	2	101-5822	ADAPTER, 4 WAY CONNECTOR
19	2	62-3468	ATT TAB ASSY, REM, SF/SB, 1 HOLE
	2	226-0046	BASEPLATE SAFETY CABLE, 36" CL III (Not Shown)
	2	229-0359	QUICKLINK, 3/8, ZP (Not Shown)
	2	290-0437	RECEIVER, CAP PLUG (BLK) (Not Shown)

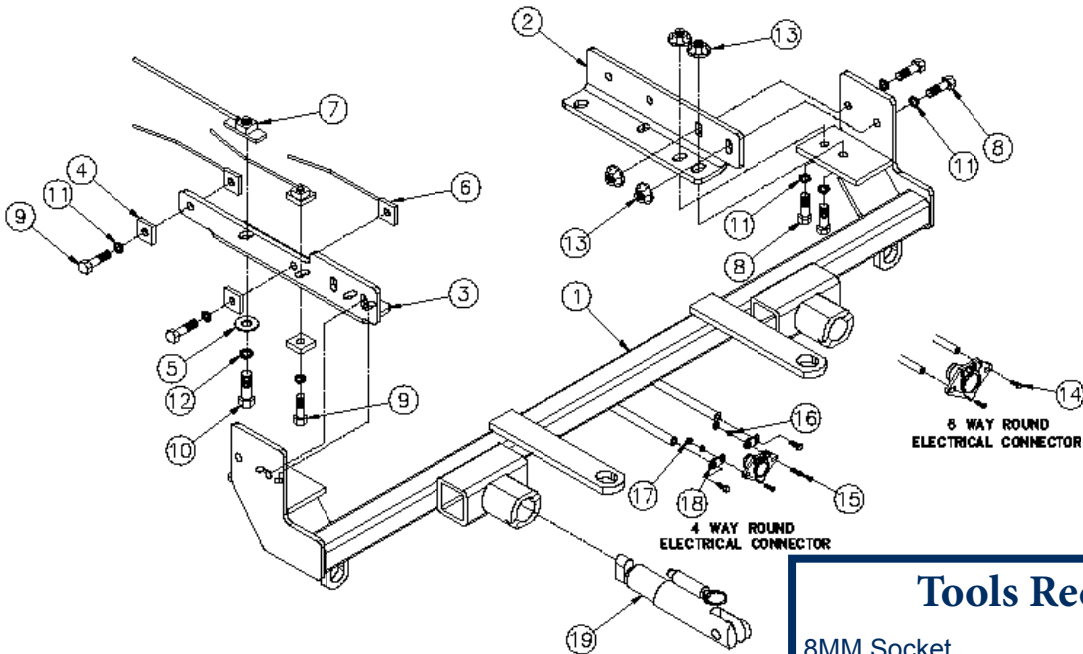

Tools Required

8MM Socket	10MM Socket
13MM Socket	16MM Socket
9/16" Socket	3/4" Socket
T-25 Torx Socket	T-30 Torx Socket
Large Vise Grip	Flat Screwdriver
Diagonal Cutters	Reciprocating Saw
Hack Saw Blade	13/32" Drill Bit
1/4" Drill Bit	17/32" Drill Bit
Loctite Red	

Important:

Use only genuine factory replacement parts on your baseplate. Do NOT substitute homemade or non-typical parts. If a bolt is lost or in need of replacement, for your safety and the preservation of your baseplate, be sure to use a replacement bolt of the same grade (In most cases it will be Grade 5, please reference the parts list above). Replacement parts may be ordered through your nearest Blue Ox® Dealer or Distributor, or call our Customer Care Team at (402)385-3051. Failing to follow and/or altering these installation instructions in either installation or required equipment will void the manufacturer's warranty. Towing behind a non-motorized vehicle will void the warranty.

BX3828 2008 VW EOS Installation Instructions

Attachment Tabs:

Motorhome mount tow bars are recommended for use with this baseplate. Due to the design of the removable tabs, the RangeFinder II, Adventurer and Ambassador tow bars can not be used. The Acclaim tow bar may be used, but will not fold and store on the front of the vehicle. Adapters, except for the BX8833 and the BX88151, can not be used with this baseplate.

Instructions:

The grille, fascia, marker light, washer reservoir, headlights, horn, horn bracket, air dam, bumper and headlight bracket are removed and reinstalled.

Trimming of frame, air dam and bumper is required. Drilling is required.

The dimensional variations between otherwise identical vehicles can be considerable. While the baseplate was designed for easy installation, it may be necessary to tailor the baseplate slightly to compensate for auto manufacturer's tolerances. These minor adjustments may include filing a hole slightly, bending electrical rods or bending end plates.

The BX8848 4 Diodes Wire Kit is recommended for this vehicle.

Handling of some cosmetic parts when installing this product may require the use of protective covers, rags, specialty tools, etc. to prevent damage.

Installation Instructions:



1. On the top edge of the fascia remove the screw in the corner with a T-25 Torx socket. Do this on both sides and set aside for later reinstallation.



2. Pull back on the two clips in order to remove the plastic. Set plastic aside for later reinstallation.

BX3828

2008 VW EOS

Installation Instructions



3. Using a T-25 Torx remove the two bolts holding the chrome. Set chrome and bolts aside for later reinstallation.



4. Remove the two screws from the bottom of the grille. To remove the grille, lift the clips in the center back to release and lift up over the top edge. Lift the clip in the corner out of the slot. Pull out of the three clips along the side to release.



5. Lift and pull out on both sides to slide the three clips out of the notches on the bottom. Some vehicles may have five clips instead of three. Set the grille aside to be reinstalled later.



6. Just behind grille, remove two T-25 Torx bolts at the top (white arrows). And two T-30 Torx bolts in the center (gray arrows). Set bolts aside to reinstall later.

BX3828 2008 VW EOS Installation Instructions



7. Just forward the front tire in the wheel well, remove two T-25 Torx screws. Set screws aside to reinstall later.



8. Pull the wheel well cover back and remove two T-25 Torx screws. Set screws aside to reinstall later. Also pull the slide bar back until it clicks to release the clips holding the fascia. Do this on both sides.



9. Under the fascia are nine Torx bolts that need to be removed with a T-25 Torx socket. Remove bolts and set aside for later installation.



10. On the back of the side marker lights, press the clip down to release. On the front, slide the light in and back, the front comes out. Pull the light out, then push the light in the opening and out the back. On the back side of the fascia on the driver's side only, detach the marker light from the clip. Unplug the running lights. Pull fascia corners out to the side, pull fascia forward to remove. Set fascia aside carryover to reinstall later.



BX3828 2008 VW EOS Installation Instructions

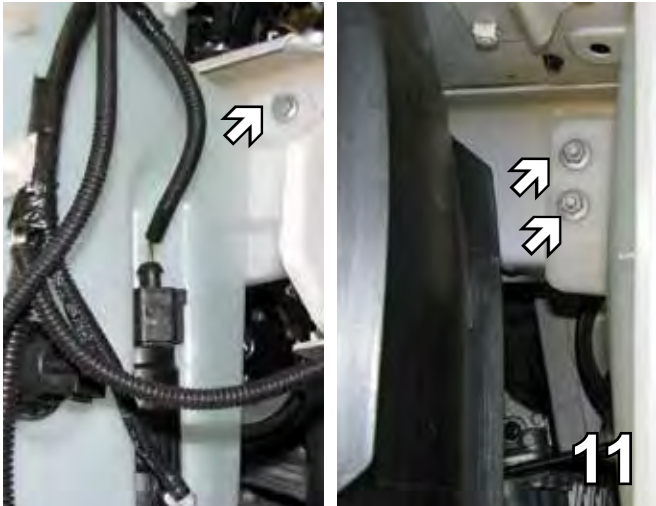

11. Using a 10MM socket, remove one bolt from the front of the washer reservoir and two from the back on the passenger side.

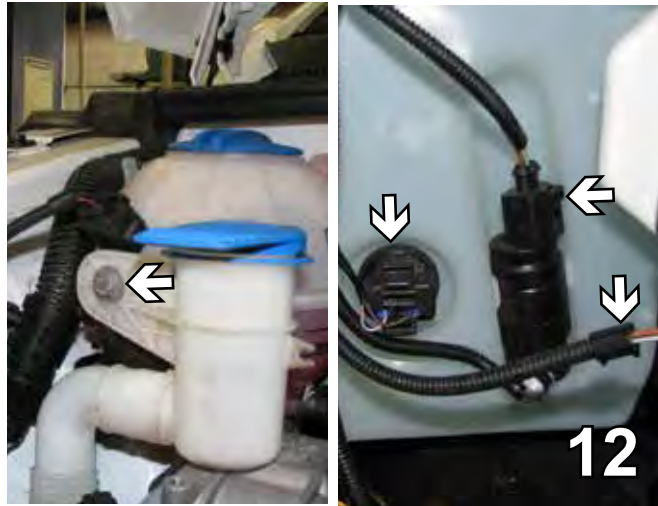

12. Use the 10MM socket to remove the bolt from the top. Disconnect the two electrical connections and the fluid line which should be plugged. Set aside for reinstallation later.

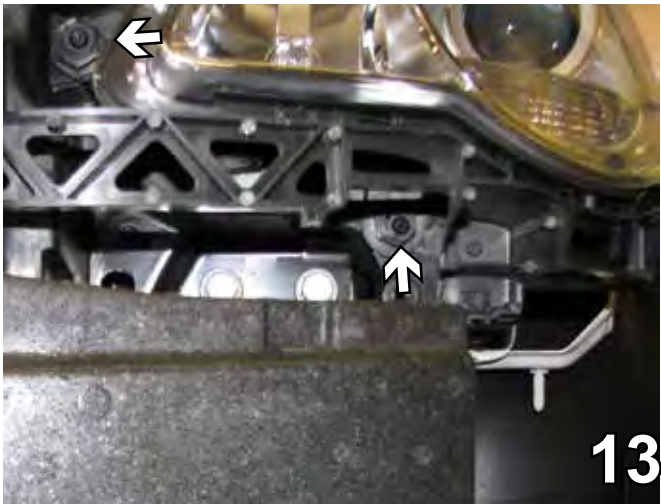

13. Use a T25 Torx to remove one bolt from the side of the headlight and one from the bottom. Do this on both sides and set aside to reinstall later.



14. Use the T25 Torx to remove the bolt from the top. Do this on both sides. Pull out the headlights, disconnect and set aside to reinstall later.

BX3828

2008 VW EOS

Installation Instructions



15. On the backside of the frame end just below the frame rail on the passenger side, use an 8MM socket to remove the two hex nuts from the horn bracket. Set aside to reinstall later.

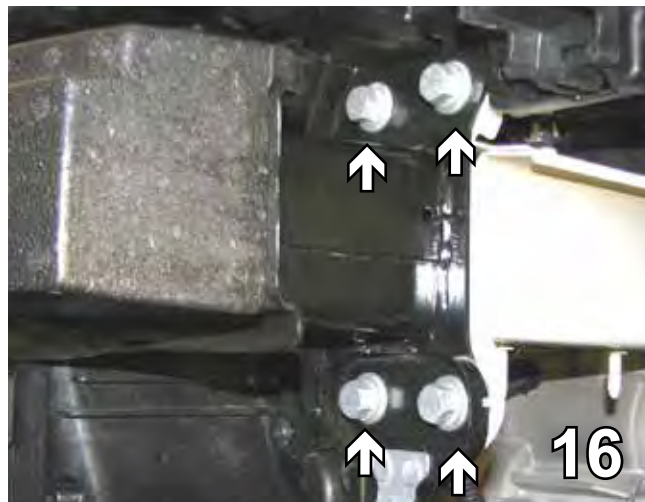

16. Use a 16MM socket to remove the two metric bolts below the headlights and the two on the bottom. Just under the bumper, press the clip down and pull the air dam off. Do this on both sides. Set aside to reinstall later.

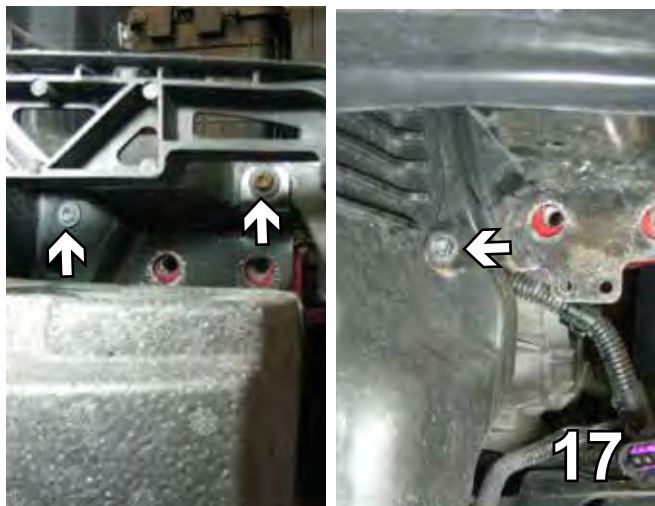

17. Use the T-30 Torx Socket to remove three bolts. Do this on both sides. Set aside for reinstallation later.

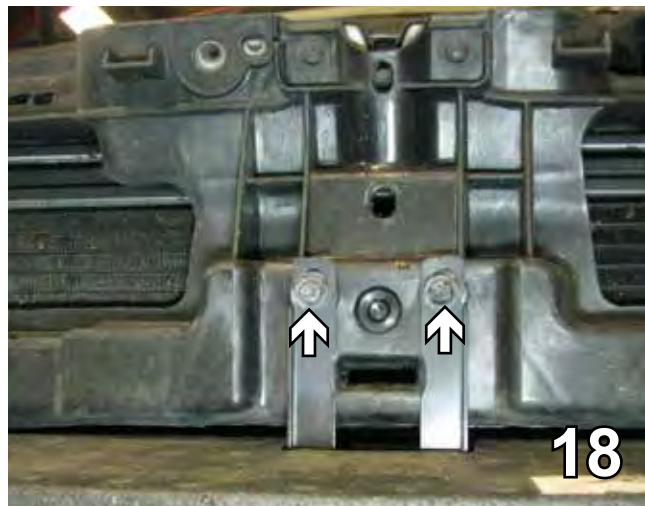

18. In the center of the radiator, use a T-30 Torx to remove the two screws. Set aside for later reinstallation.

BX3828 2008 VW EOS Installation Instructions



19. On the driver's side, use an 8MM socket to remove the hex nuts holding the horn bracket. Unplug the wire (gray arrow) and set the horn bracket aside to install later.

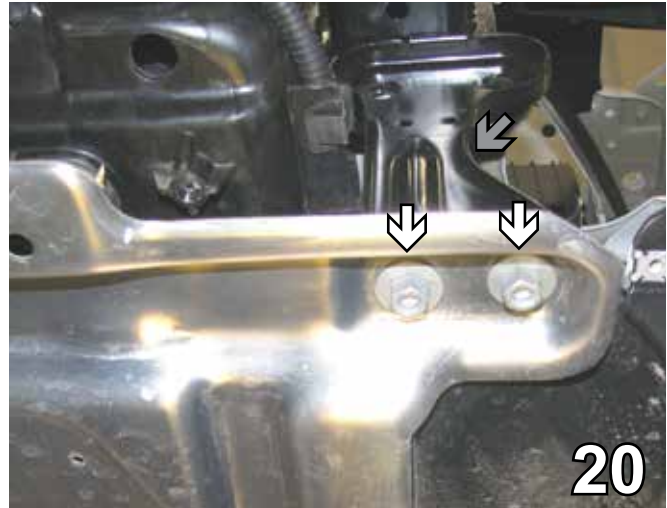

20. Underneath on the belly pan, use a 13MM socket to remove the two hex nuts. Do this on both sides. Take the brace out (gray arrow) in order to remove the bumper. Set all aside to reinstall later. Do this to both sides.



21. Remove the temperature sensor on the driver's side. Turn it around and reinstall so that it is pointing up not down.

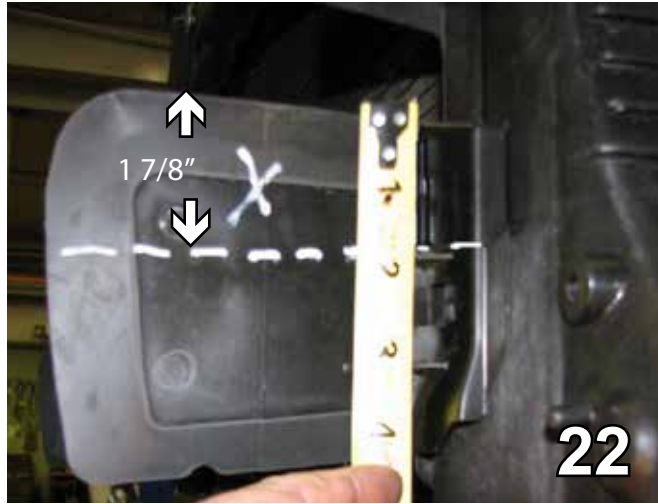

22. Trim the air dam 1 7/8" down from the top and all the way across. Do this on both sides.

BX3828 2008 VW EOS Installation Instructions

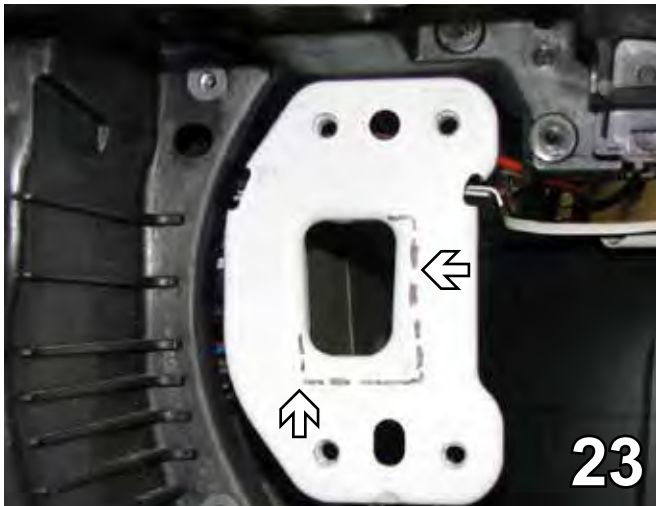

23. On the frame rail end, cut with a reciprocating saw even with the inside of the frame and down. Be sure not to cut into the frame. Do this on both sides. Photo shows driver's side.



24. Be careful not to cut the nut for the washer reservoir on the inside of the frame on the passenger side.

Using a good quality paint, spray cut edges of frame to prevent rusting.



25. On the back side of the bumper with the right side up, cut straight across the opening and straight down following the inside of the extension, then straight across the bottom. Be sure not to cut into the frame. Do this on both sides. Driver's side shown.

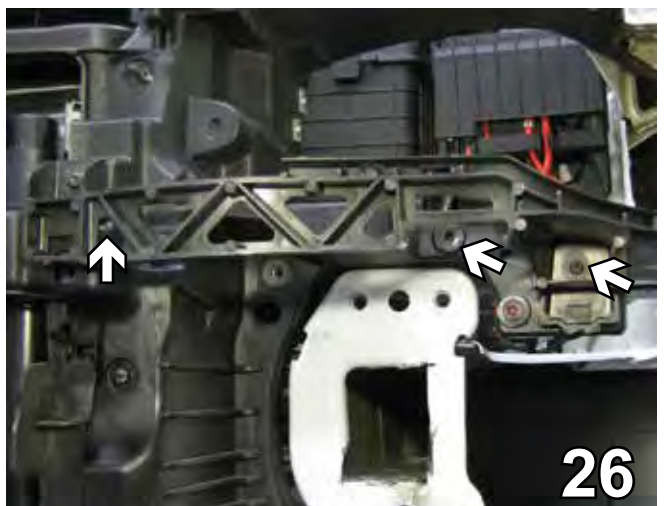

26. Use a T-25 Torx socket to remove the three bolts holding the headlight lower bracket on both sides. Set the bracket and bolts aside to reinstall later.

BX3828 2008 VW EOS Installation Instructions



27. On the passenger side on the bottom of the frame, use a pliers to wiggle the stud off.

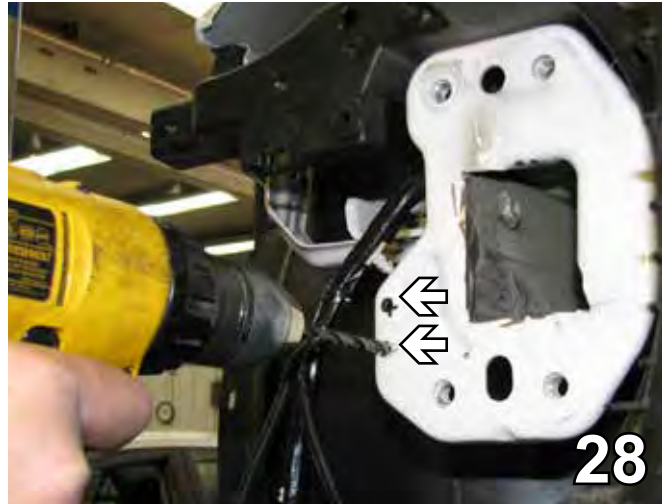

28. On the passenger side only, measure the distance between the bolts on the horn bracket, mark the frame rail end and drill with a 1/4" bit.

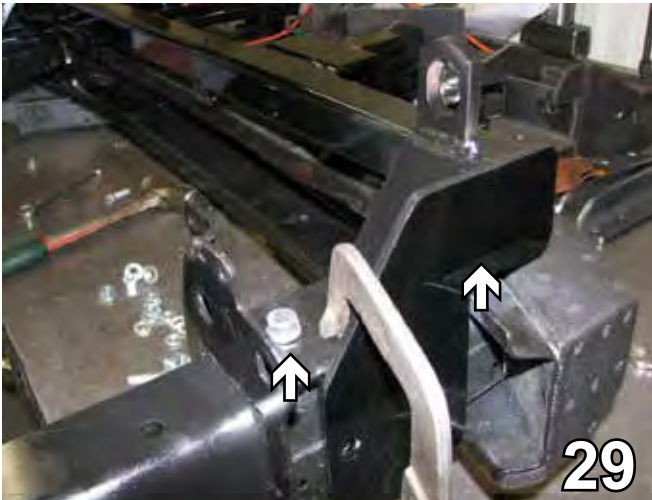

29. With the bumper upside down, slide the baseplate upside down over the outside frame extension and clamp. Align the baseplate with existing hole in the bottom of the bumper extension. Slide the driver's side frame extension bracket inside and align with the second hole back. Insert 3/8-16 x 1 1/4" bolt with 3/8" lock washer and 3/8" whiz nut. Do this on both sides.

When using power drills be aware of the dangers of torque and drill bit length.

30. Using the baseplate as a template drill three holes, one on the top and two on the side with a 13/32" drill bit. Do this on both sides.

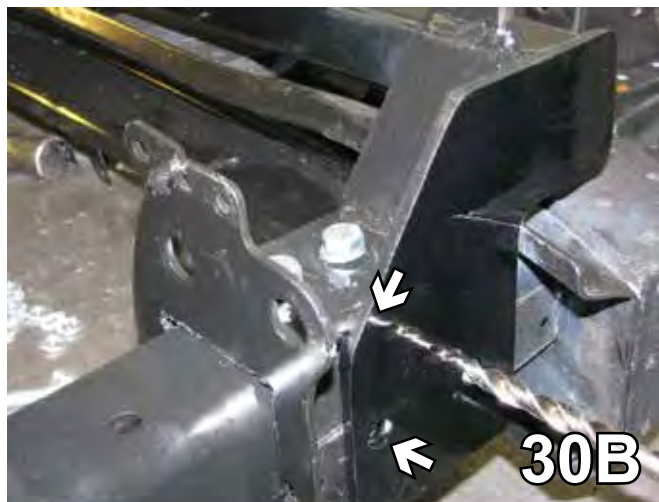
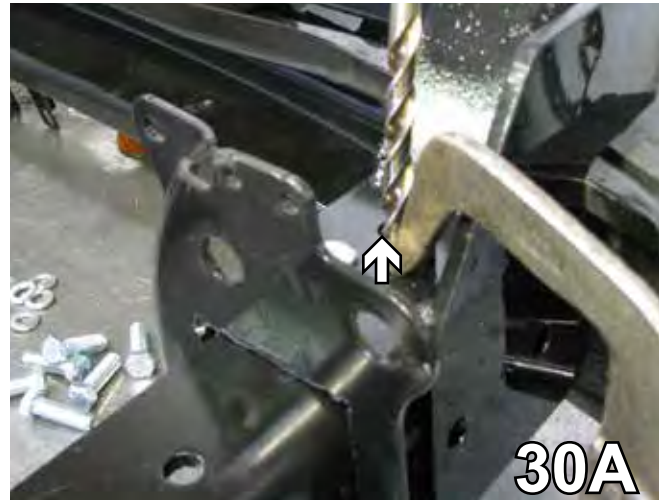

BX3828 2008 VW EOS Installation Instructions

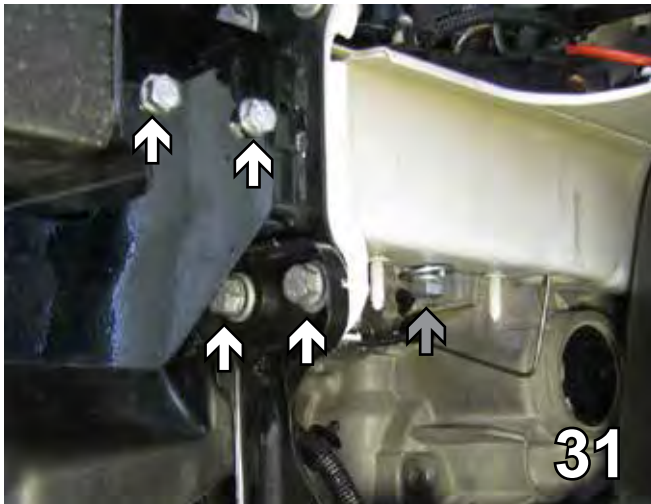

31. Use Loctite and loosely attach all four 3/8-16 x 1 1/4" bolts, 3/8" lock washers and 3/8-16 whiz nuts. Line up the back hole and loosely attach a 1/2-13 hex bolt, 1/2" lock washer, 1/2" flat washer and 61-3799 1/2" nut plate (gray arrow). Do this on both sides. Then tighten up the first four bolts. Reinstall the bracket above the belly pan and the horn brackets on both sides.



32. If the two bottom holes of step 30 do not line up, it may be necessary to separate the belly pan from fender well plastic using the T-25 Torx to remove the three torx bolts on both sides. Pull wheel well plastic back to ream existing holes.

****BE SURE TO USE LOCTITE® RED ON ALL BOLTS BEFORE TIGHTENING. TIGHTEN ALL BOLTS ACCORDING TO THE TORQUE CHART ON PAGE 1 OF THESE INSTRUCTIONS OR ON PAGE 3 OF THE BASEPLATE TOWING GENERAL INSTRUCTIONS.**



33. Install the 3/8-16 hex bolt, 3/8" lock washer, 1/4 x 1 x 1" nut plate in the front hole on the bottom of the frame and tighten into 3/8-16 nut plate. Do this on both sides.

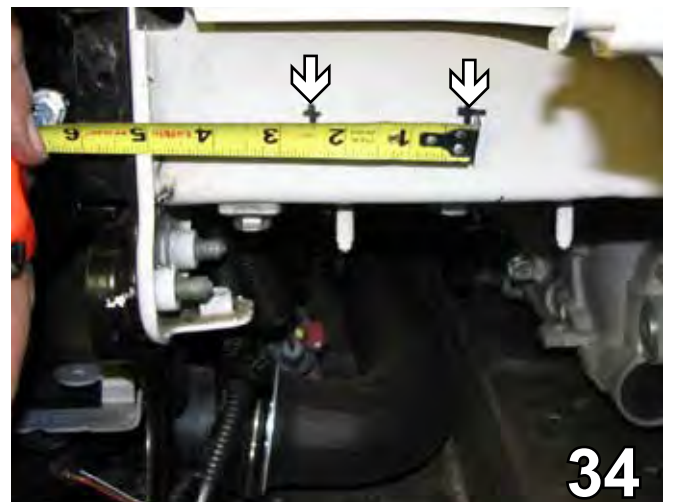

34. On the driver's side, measure up 1 1/4" and over 5" from the back side of the frame end, the next 2 1/2" back, drill first with a 1/4" bit then back it up using a 13/32" drill bit.

BX3828 2008 VW EOS Installation Instructions

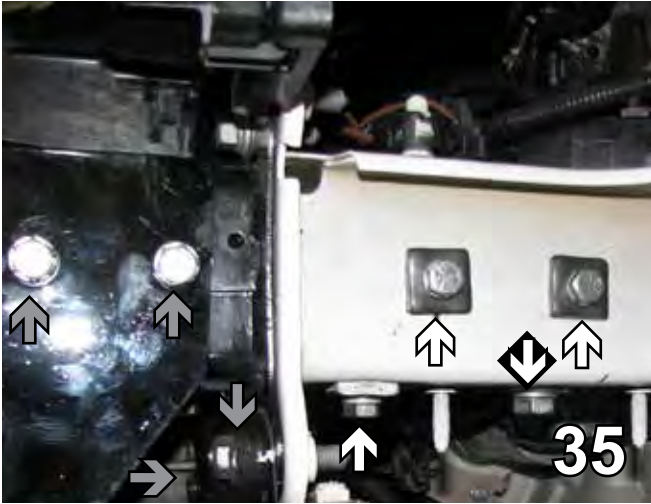

35. Use 3/8-16 nut plates on the inside attached to 3/8-16 x 1 1/2" bolts with Loctite, 3/8" lock washers and 1/4 x 1 x 1" nut plates (white arrows). Four bolts (gray arrows) are 3/8-16 x 1 1/4" with Loctite, 3/8" lock washers and 3/8-16 whiz nuts.



36. On the passenger side, drill a 13/32" hole 1 1/4" up and 3/4" back from the back of the frame end.



37. Insert nut plates, align with the drilled holes, then tighten 3/8-16 x 1 1/2" hex bolt, 3/8" lock washer, 1/4 x 1 x 1" nut plate into both holes. Be sure 1/4 x 1 x 1" plate is square with the frame to give enough room for the reservoir.



38. On the back side of the washer reservoir, mark a line 3/4" away from the back rib and 1 1/4" up from the bottom frame edge. Cut below the rib all the way down.

39. Reinstall the horns on both sides. On the passenger side, reinstall into the drilled holes, see step 28, using the existing nuts.

BX3828

2008 VW EOS

Installation Instructions



40. On the passenger side, reinstall the washer reservoir. Reconnect the electrical wires and the hoses to the washer reservoir.

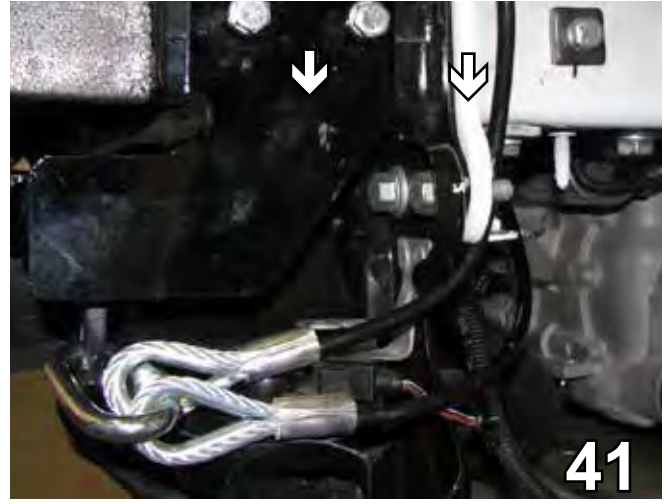

41. On the driver's side, hook the permanent baseplate safety cables around the frame end and under the wires. Do this on both sides.



42. Put the headlight brackets and the headlights back in and reconnect.

43. Reinstall the bumper and carefully reattach electrical wires. Reinstall the air dam, fascia, marker light, grille and replug the running lights.

44. Align the fascia to its original position and using a hack saw blade, remove area around attachment tab receiver to allow for it to come through fascia. Do this to both sides of the vehicle.



BX3828 2008 VW EOS Installation Instructions

Be sure that ALL electrical connections are plugged in properly and functioning BEFORE Installing the fascia.

DEALER or INSTALLER:

Be certain the user receives the instruction sheets for their products.



If the baseplate is in an accident, it must be replaced. DO NOT use it again! An accident can cause unseen damage and using it again could result in more damage or serious injury. DO NOT use the baseplate if it is damaged or missing parts.

CUSTOMER SERVICE COMMITMENT

Blue Ox is committed to providing you with exceptional customer care throughout your lifetime with our products. Our team is here to assist you with any questions you may have regarding the performance of your product. Simply call 1-(402) 385-3051 and you can speak with our customer care team.

Additionally, please visit our website to see which rallies our Destination America team will be attending. For a nominal fee, our service technician will service your towing system to ensure it's in proper working condition. Also as a commitment to our customers, should you visit our factory you can stay at our full service Blue Ox campground at no charge along with enjoying a factory tour.

Again thank you for being our customer and for the confidence you have shown in the performance of our products. It is because of customers like you we enjoy the success we have today.



© 2005, 06, 10 Blue Ox
One Mill Road, Industrial Park
Pender, Nebraska 68047
Phone: (402) 385-3051
Toll Free: (888) 425-5382
Fax: (402) 385-3360
www.blueox.com

General Information

1. Ensure that your product(s) are registered online at www.blueox.com. It is crucial to register your product(s) so that you may be alerted of product offerings, updates, upgrades, maintenance and safety bulletins, and/or recalls.
2. **It is the owner's responsibility to inspect all towing equipment for cracked welds, missing or worn parts and loose bolts before each towing trip.** Be sure to use Loctite® Red on all bolts and tighten to the recommended specifications.
3. **It is the owner's responsibility to hook up all towing equipment per manufacturer's instructions/recommendations.**
4. Remove the attachment tabs when not in use (if applicable).

Notice To Baseplate Installer

1. It is YOUR responsibility to watch for:

- Oil cooler and air conditioner lines
- Electrical wires and hoses
- Missing parts or attaching points on the frame

** If the baseplate is improperly installed and is against a wire or hose, it could cause fluid leaks or electrical shorts some time after the actual baseplate installation.

Permanent Baseplate Safety Cable Installation

Permanent baseplate safety cables are strongly recommended when towing a vehicle with a tow bar. The principle function of the permanent baseplate safety cables is to prevent the towed vehicle from breaking loose in the event the connection between the frame of the towed vehicle and the baseplate fails or becomes disconnected. The cables must be connected from the baseplate to the frame rail or cross member of the vehicle's frame. The illustrations below show the possible arrangements recommended by Blue Ox®. Each permanent baseplate safety cable must have an adequate weight rating for the towing system. The weight rating of the two (2) cables together will not qualify.

Do not mount the permanent baseplate safety cables against wires, hoses or brake lines.

These permanent baseplate safety cables should remain installed as long as the baseplate is installed on the vehicle. Permanent baseplate safety cables are to be used in conjunction with, and NOT a replacement for legally required safety cables attaching the towed vehicle to the towing vehicle.

OPTION #1

Permanent Baseplate Safety Cables to Cross Member or Frame of Towed Vehicle.

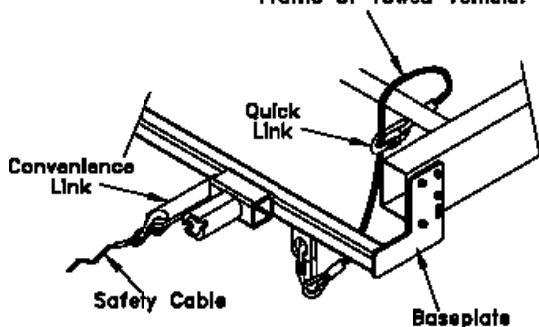

OPTION #2

Permanent Baseplate Safety Cables to Cross Member or Frame of Towed Vehicle.

