

**Please read BOTH these Installation Instructions and the General Towing Instructions before attempting to install or operate this equipment.**

1. Blue Ox® towing products and accessories are intended to be installed by Blue Ox® Dealers who are familiar with our products and have the equipment and knowledge to do “fit work.” When necessary, Blue Ox® Dealers can be found at [www.blueox.us](http://www.blueox.us) or by contacting our 24/7 Customer Care Department at (888) 425-5382.

Attachment Tab Height: 26”  
Attachment Tab Width: 24.5”

2. Many Blue Ox® Baseplates are designed to use existing holes and hardware to mount the baseplate to the towed vehicle. Even though bolts are there, do not assume they are adequate for baseplate mounting. Always use hardware supplied in the hardware kit or existing hardware specified in the Baseplate Towing Installation Instructions.

**Bolt Torque Specifications**

Torque in Foot-Pounds per Metric Bolts

Bolt Size	Grade 8.8	Grade 10.9
6MM	6	8
8MM	16	22
10MM	31	40
12MM	54	70
14MM	89	117

Confirm the towability and pre-towing procedures for your vehicle with the owner’s manual or contact the vehicle’s manufacturer for specific towing procedures. You can also contact REMCO for additional information at 1(800)228-2481.

**Bolt Torque Specifications**

Torque in Foot-Pounds per Inch Bolts

Bolt Size	Grade 5	Grade 8
1/4”	10	14
5/16”	19	29
3/8”	33	47
7/16”	54	78
1/2”	78	119
5/8”	154	230



**! WARNING**

Failure to read and follow these instructions could result in separation of the towed vehicle from the tow bar, causing property damage, loss of towed vehicle, personal injury or death.

# BX1979

2007 Dodge Ram 1500 Mega Cab 4 x 4

2008 Dodge Ram 1500 SXT Reg Cab

## Installation Instructions

### Parts List

Ref. No.	Qty.	Part #	Description
1	1	61-6411	WLDM'T, BASEPLATE, BX1979
2	6	61-4029	WELDMENT, 1/2 NUT WIRE COMMON
3	6	201-0051	1/2-13 X 1 1/2 HEX BOLT GRD.5, ZP
4	4	201-0581	1/2-13 X 4 HEX HD BOLT, GRD 5, ZP
5	10	203-0012	1/2 LOCK WASHER, ZP
6	6	203-0005	1/2 FLAT WASHER, ZP
7	4	202-0005	1/2-13 HEX NUT, ZP
8	2	201-0979	#12-14 x 1" Self Drilling Screw, ZP
9	2	201-0192	10-32 X 1/2 SLOT, RD. HD. SCREW
10	2	203-0054	#10 LOCK WASHER
11	2	202-0047	#10-32 HEX NUT
12	2	101-5822	ADAPTER, 4 WAY CONNECTOR
13	2	62-3469	ATT TAB ASSY, REM, SF/LB, 1 HOLE
	2	226-0049	BASEPLATE SAFETY CABLE, 36" CLASS IV (NOT SHOWN)
	2	229-0512	QUICKLINK, 1/2, ZP (NOT SHOWN)
	2	290-0437	RECEIVER, CAP PLUG (BLK) (NOT SHOWN)

### Tools Required

Loctite® RED

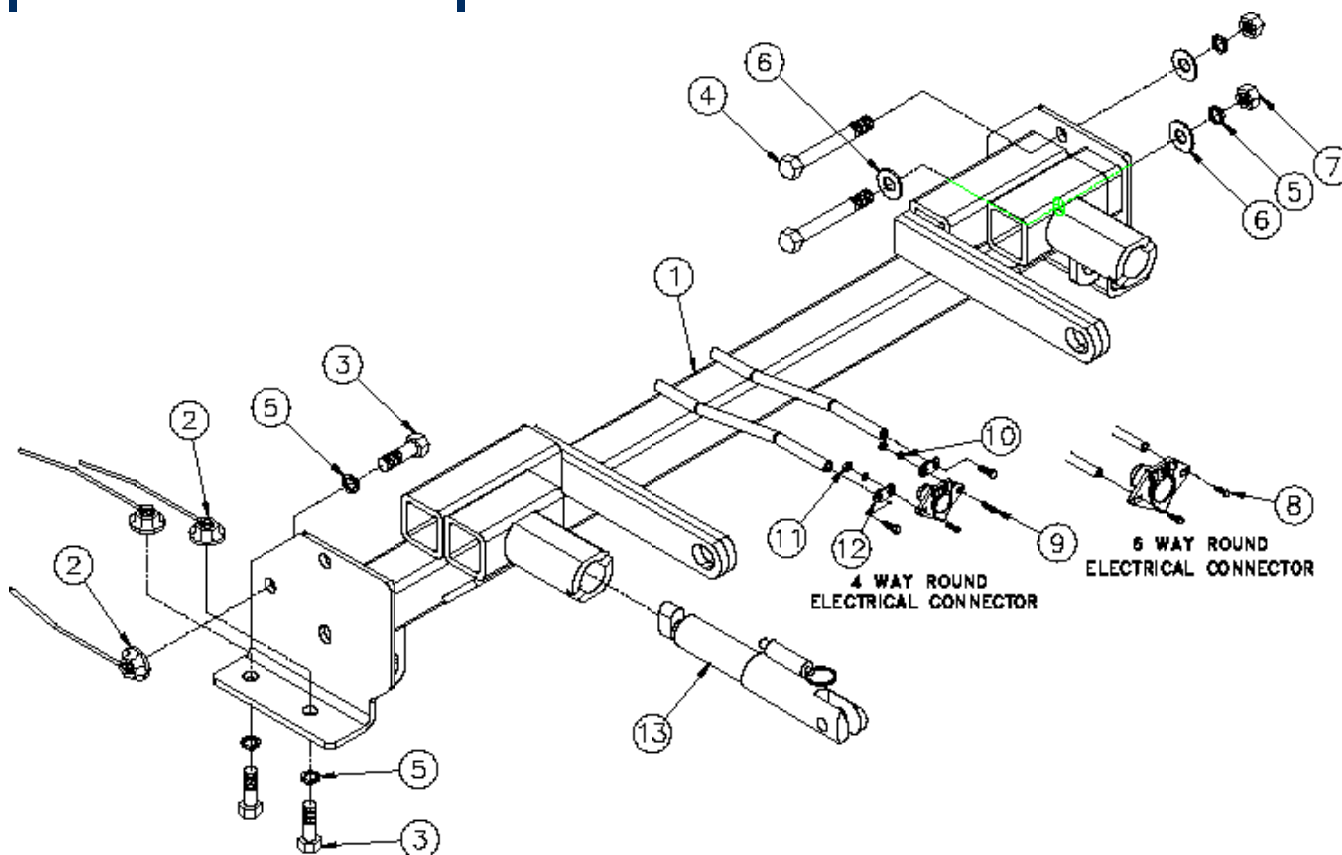

Use only genuine factory replacement parts on your baseplate. Do **NOT** substitute homemade or non-typical parts. If a bolt is lost or in need of replacement, for your safety and the preservation of your baseplate, be sure to use a replacement bolt of the same grade (In most cases it will be Grade 5, please reference the parts list above). Replacement parts may be ordered through your nearest Blue Ox® Dealer or Distributor.

# BX1979

## 2007 Dodge Ram 1500 Mega Cab 4 x 4 2008 Dodge Ram 1500 SXT Reg Cab Installation Instructions

### Vehicle Weight:

The weight of this vehicle is near the Class III, 5,000 lb. rating limitations. Some models, depending on options, may well exceed this 5,000 lb. rating. Be sure to confirm the weight of your individual vehicle before towing. As of 1999, the Aventa® II is now 10,000 lbs. and either the Aventa® II or the Aventa® LX tow bar must be used for these applications.

**Tow Bar Adapters are NOT to be used with vehicles weighing over 5,000 lbs.**

**Installation Notes:** The fascia and metal bumper are removed and reinstalled during installation of the baseplate. Drilling is required. Trimming of the fascia is required.

The dimensional variations between otherwise identical vehicles can be considerable. While the baseplate was designed for easy installation, it may be necessary to tailor the baseplate slightly to compensate for auto manufacturer's tolerances. These minor adjustments may include filing a hole slightly, bending electrical rods and/ or bending end plates.

The BX8869 Bulb and Socket Wiring Kit is recommended for this vehicle.

### Installation Instructions:



1. Using a T27 Torx socket remove three torx head bolts from the wheel well just forward the front tire. Do this to both sides and set push pins aside for later reinstallation.

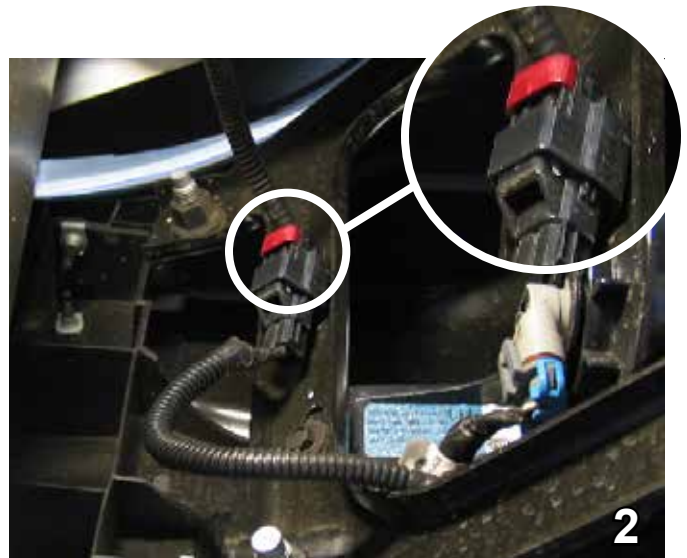

2. Located behind the pumper is a red cap on plug. Slide red cap up then push in to release plug, set plug up out of the way.

# BX1979

2007 Dodge Ram 1500 Mega Cab 4 x 4 2

008 Dodge Ram 1500 SXT Reg Cab

## Installation Instructions

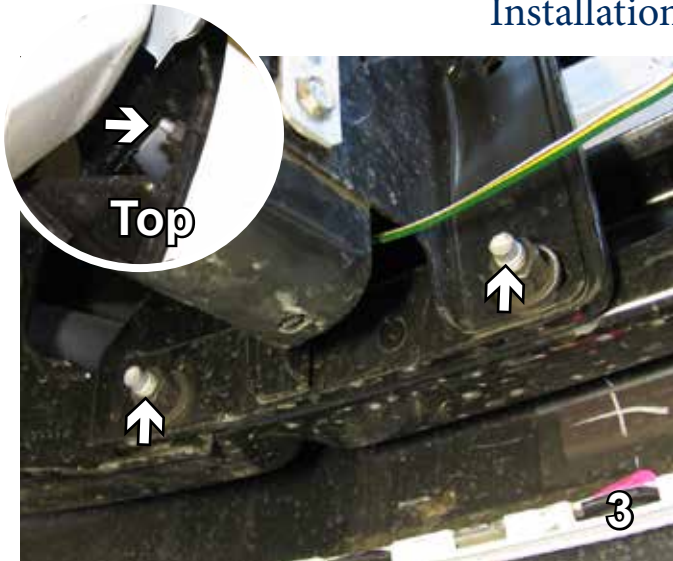

3. Using an 18MM socket, remove three bolts from behind the bumper - two on the bottom, one on the top. Do this on both sides.



4. After removing the bumper, take an 18MM socket to remove the two hex nuts and bolt plates from the bumper bracket on frame rail end. The bolt plate and hex nut will not be reinstalled. Do this to both sides.



5. NOTE: The following step require two people to complete. Doing otherwise is dangerous and can cause injury.

While holding bumper brackets in place align baseplate to the interior hole and insert 1/2-13 x 4" bolts and flat washers on both sides. before tightening, adjust bumper bracket to the previous height, then slide baseplate up to the bottom of the frame and tighten bolt and hex nuts.

**NOTE: Mark the height of bumper bracket on frame.**



6. Using the baseplate as a template, take a 17/32" drill bit and drill the bottom two holes. Do this to both sides. Install the 1/2 x 1 1/2" nut plate and lock washers into the two holes.

**BE SURE TO USE LOCTITE® RED ON ALL BOLTS BEFORE TIGHTENING. TIGHTEN ALL BOLTS ACCORDING TO THE TORQUE CHART ON THE FRONT PAGE OF THESE INSTRUCTIONS OR ON PAGE 3 OF THE BASEPLATE TOWING GENERAL INSTRUCTIONS.**

## BX1979

### 2007 Dodge Ram 1500 Mega Cab 4 x 4 2008 Dodge Ram 1500 SXT Reg Cab Installation Instructions



7. Drill 1 1/4" hole with a 1 1/4" hole saw in the center of the frame rail to place nut plates. After making sure bottom hex nut is tight, remove top bolt and use Loctite Red and tighten, then do the same to the bottom hex nut. Do this on both sides.



8. Using the baseplate as a template, drill with the 17/32" drill bit the back hole located on the top of the baseplate. Do this to both sides.

Be sure that **ALL** electrical connections are plugged in properly and functioning **BEFORE** installing the fascia.

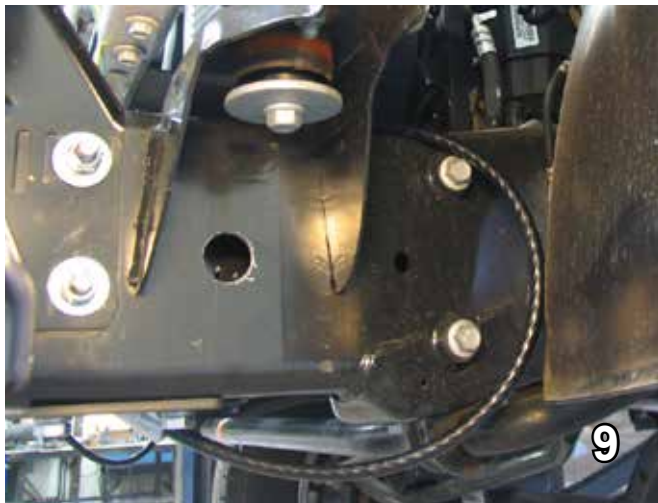

9. Install the safety cables as directed, around the frame rail suspension support of the vehicle.



- 9B. Quick link the safety cables to the convenience link on baseplate. Reinstall fascia. Do this to both sides.

BX1979

2007 Dodge Ram 1500 Mega Cab 4 x 4 2

008 Dodge Ram 1500 SXT Reg Cab

### Installation Instructions

Install the tow bar and safety cables according to the instructions provided in their packages. When demonstrating this to the customer, be sure to include all the contents and packages.

Do **NOT** substitute other devices if the tow bar pins and clips are misplaced.

**DEALER or INSTALLER:**  
**Be certain the user receives the instruction sheets for their products.**

### Customer Service Commitment

Blue Ox® is focused on providing exemplary customer service, as observed in our mission statement and guiding principles. In accordance with this objective, Blue Ox® is proud to provide services such as repairs and general maintenance of Blue Ox® products at over 150 RV Rallies. Look for our Destination America or Blue Ox® Racing service crews at the next rally or race that you attend. If you were not present, you will find an informative, personalized note explaining any services that may have been performed to your Blue Ox® products.

Blue Ox® also offers educational seminars at rallies and through our Park and Resort teams. In addition, Blue Ox® customers visiting our factory may take advantage of the well-equipped Blue Ox® RV park at no charge to you, our valued and appreciated customer.



© 2007 Blue Ox  
One Mill Road, Industrial Park  
Pender, Nebraska 68047  
Phone: (402) 385-3051 • Fax: (402) 385-3360  
[www.blueox.us](http://www.blueox.us)

# General Information

1. Ensure that your product(s) are registered online at [www.blueox.com](http://www.blueox.com). It is crucial to register your product(s) so that you may be alerted of product offerings, updates, upgrades, maintenance and safety bulletins, and/or recalls.
2. **It is the owner's responsibility to inspect all towing equipment for cracked welds, missing or worn parts and loose bolts before each towing trip.** Be sure to use Loctite® Red on all bolts and tighten to the recommended specifications.
3. **It is the owner's responsibility to hook up all towing equipment per manufacturer's instructions/recommendations.**
4. Remove the attachment tabs when not in use (if applicable).

## Notice To Baseplate Installer

### 1. It is YOUR responsibility to watch for:

- Oil cooler and air conditioner lines
- Electrical wires and hoses
- Missing parts or attaching points on the frame

\*\* If the baseplate is improperly installed and is against a wire or hose, it could cause fluid leaks or electrical shorts some time after the actual baseplate installation.

## Permanent Baseplate Safety Cable Installation

Permanent baseplate safety cables are strongly recommended when towing a vehicle with a tow bar. The principle function of the permanent baseplate safety cables is to prevent the towed vehicle from breaking loose in the event the connection between the frame of the towed vehicle and the baseplate fails or becomes disconnected. The cables must be connected from the baseplate to the frame rail or cross member of the vehicle's frame. The illustrations below show the possible arrangements recommended by Blue Ox®. Each permanent baseplate safety cable must have an adequate weight rating for the towing system. The weight rating of the two (2) cables together will not qualify.

***Do not mount the permanent baseplate safety cables against wires, hoses or brake lines.***

These permanent baseplate safety cables should remain installed as long as the baseplate is installed on the vehicle. Permanent baseplate safety cables are to be used in conjunction with, and NOT a replacement for legally required safety cables attaching the towed vehicle to the towing vehicle.

### OPTION #1

Permanent Baseplate Safety Cables to Cross Member or Frame of Towed Vehicle.

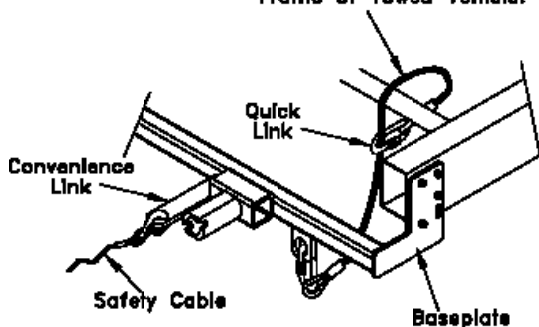

### OPTION #2

Permanent Baseplate Safety Cables to Cross Member or Frame of Towed Vehicle.

