



## BX2177 Installation Instructions

2005-10 F-350, 2wd/ 4wd, Incl. Super Duty

Serial No.

The cross member, lower air dam, and tow hooks are removed for baseplate installation. Tow hooks are not reinstalled. Holes need to be drilled. Attachment tabs are 28 3/8 inches center to center and 25 inches in height. The BX8869 is available for the vehicle.



1. Using the 21MM socket, remove three (3) bolts on cross member, both sides. Set cross member aside.



2. Remove nine (9) bolts from the plastic air dam, just under metal bumper, with the 6MM socket.



3. Just forward of front leaf springs and behind metal bumper, are three (3) bolts on tow hook to remove using the 15MM socket. Pull tow hook forward and set aside, both sides. Tow hooks will **NOT** be reinstalled.



4. With the 18MM socket, remove the two (2) bolts from metal bumper openings, on both sides.



5. Hold baseplate into opening for tow hook to align with back hole, insert a 1/2"-13 x 1-3/4" bolt with a 1/2" lock washer and tighten. Refer to drawing on last page. **Be sure and use loctite on all bolts before tightening.**

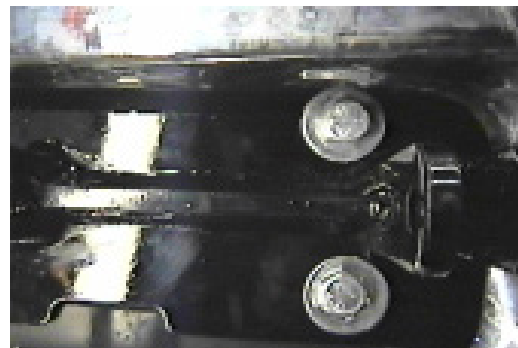

6. Reinstall four (4) existing bolts and tighten. Using the 17/32" drill bit, drill out remaining holes in baseplate. **Be sure and use loctite on all bolts before tightening.**



7. Insert 1/2"-13 x 1-3/4" bolts into the face of the baseplate and install 1/2" lock washers and 1/2"-13 hex nuts on the back side of metal bumper. Install the remaining two (2) 1/2"-13 x 1-3/4" bolts with 1/2" lock washers into the existing tow hook holes on the bottom side. Do this on both sides of the vehicle. Tighten all hardware. **Be sure and use loctite on all bolts before tightening.**

8. Reinstall plastic air dam and cross member.

9. *The dimensional variations between otherwise identical cars can be considerable. While the baseplate was designed for easy installation, it may be necessary to tailor the baseplate slightly to compensate for auto manufacturers' tolerances. These minor adjustments may include filing a hole slightly, bending electrical rods, adding shims and/ or bending endplates.*

10. *Install the tow bar and safety cables according to the instructions included in their packages.*

11. *Do not substitute other devices if the tow bar pin and clip are lost.*



2005 F-350

## Tools Required

8MM Socket  
15MM Socket

21MM Socket  
3/4" Socket

17/32" Drill Bit  
Vise Grips  
Loctite Red

### Parts List

	Ref. No.	Qty.	Part No.	Description
1	1	1	61-6125	Weldment, Base Plate, DS, BX2177
2	1	1	61-6126	Weldment, Base Plate, PS, BX2177
3	1	1	101-6135	Electrical, Bracket, BX2160
4	4	4	201-0050	1/4-20 x 3/4 Hex Bolt, Grd. 5, ZP
5	10	10	201-0068	1/2-13 x 1 3/4 Hex Bolt, Grd. 5, ZP
6	2	2	201-0192	#10-32 x 1/2 Slot, Rd. Hd. Screw
7	4	4	202-0005	1/2-13 Hex Nut, ZP
8	2	2	202-0047	#10-32 Hex Nut
9	4	4	202-0069	1/4-20 Hex Whiz Nut, Loc, ZP
10	2	2	203-0001	1/4 Flat Washer, ZP
11	4	4	203-0008	1/4 Lock Washer, ZP
12	10	10	203-0012	1/2 Lock Washer, ZP
13	2	2	203-0054	#10 Lock Washer, ZP
		2	226-0049	Baseplate Safety Cable, 36" CL IV (Not Shown)
		4	229-0512	Quicklink, 1/2, ZP (Not Shown)
18	4	4		Existing Metric Bolts

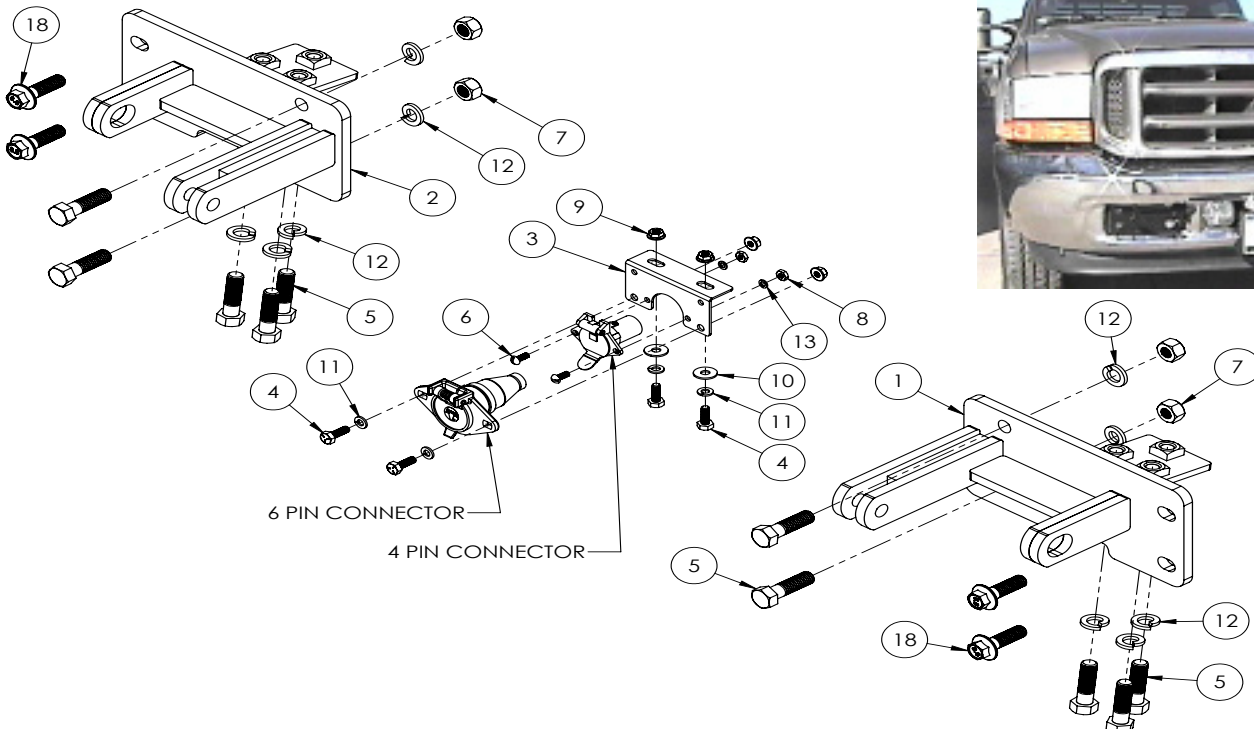

**IMPORTANT:** Use only genuine factory replacement parts on your Base Plate. Do not substitute homemade or nontypical parts. If a bolt is lost or in need of replacement, for your safety and the preservation of your Base Plate, be sure to use a replacement bolt of the same grade (Usually Grade 5, refer to parts list). Repair parts may be ordered through your nearest **Blue Ox** dealer or distributor. Failing to follow and/or altering these installation instructions in either installation or required equipment will void the manufacturer's warranty. Towing behind a non-motorized vehicle will void

© 2005, 07, 08, 09, 10 Blue Ox Division, Automatic Equipment Mfg. Co. • One Mill Road, Industrial Park

# General Information

1. Ensure that your product(s) are registered online at [www.blueox.com](http://www.blueox.com). It is crucial to register your product(s) so that you may be alerted of product offerings, updates, upgrades, maintenance and safety bulletins, and/or recalls.
2. **It is the owner's responsibility to inspect all towing equipment for cracked welds, missing or worn parts and loose bolts before each towing trip.** Be sure to use Loctite® Red on all bolts and tighten to the recommended specifications.
3. **It is the owner's responsibility to hook up all towing equipment per manufacturer's instructions/recommendations.**
4. Remove the attachment tabs when not in use (if applicable).

## Notice To Baseplate Installer

### 1. It is YOUR responsibility to watch for:

- Oil cooler and air conditioner lines
- Electrical wires and hoses
- Missing parts or attaching points on the frame

\*\* If the baseplate is improperly installed and is against a wire or hose, it could cause fluid leaks or electrical shorts some time after the actual baseplate installation.

## Permanent Baseplate Safety Cable Installation

Permanent baseplate safety cables are strongly recommended when towing a vehicle with a tow bar. The principle function of the permanent baseplate safety cables is to prevent the towed vehicle from breaking loose in the event the connection between the frame of the towed vehicle and the baseplate fails or becomes disconnected. The cables must be connected from the baseplate to the frame rail or cross member of the vehicle's frame. The illustrations below show the possible arrangements recommended by Blue Ox®. Each permanent baseplate safety cable must have an adequate weight rating for the towing system. The weight rating of the two (2) cables together will not qualify.

***Do not mount the permanent baseplate safety cables against wires, hoses or brake lines.***

These permanent baseplate safety cables should remain installed as long as the baseplate is installed on the vehicle. Permanent baseplate safety cables are to be used in conjunction with, and NOT a replacement for legally required safety cables attaching the towed vehicle to the towing vehicle.

### OPTION #1

Permanent Baseplate Safety Cables to Cross Member or Frame of Towed Vehicle.

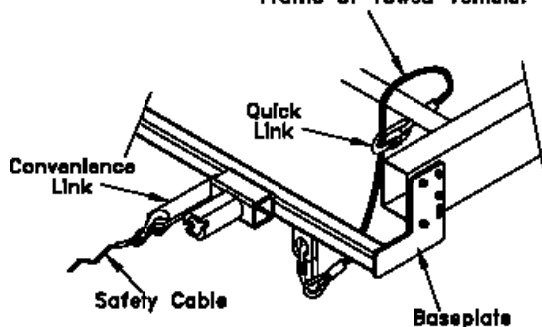

### OPTION #2

Permanent Baseplate Safety Cables to Cross Member or Frame of Towed Vehicle.



# BLUE OX ORIGINAL PURCHASERS THREE YEAR LIMITED WARRANTY

Automatic Equipment Manufacturing Company ("Automatic") warrants to the original (first) retail purchaser that this product, manufactured by Automatic, shall be free from defect in material and workmanship under normal use and service for a period of three years from the date of delivery.

During said three-year period, Automatic will repair or replace any parts that have been returned by the original purchaser, to the factory, transportation prepaid, and in Automatic's sole and absolute opinion found to be defective.

Limitations on Warranty Coverage:

Coverage under this warranty will be valid only if the customer warranty card is returned by the original purchaser within 30 days of purchase.

Coverage under this warranty will be effective only when a copy of the original invoice, showing date and place of purchase, accompanies any claim for warranty. This warranty is NON TRANSFERABLE.

This limited warranty will not cover, in any way or form, any alleged damages caused by incorrect or improper installation, improper use, modification or neglect of product, failure to properly service and maintain, misuse, act of God, accident or failure of the user to follow guidelines contained in the instructional material provided by Automatic.

This warranty does not cover normal wear and tear, paint or rust.

Warrantor assumes no responsibility to the owner for loss of use of product, loss of time, inconvenience or any other damage consequential or otherwise. Including, but not limited to mileage, expense of transporting of product, return shipping expense, mechanics travel time, telephone, road service, towing, and rental during repairs, travel, lodging, loss or damage to personal property or loss of earnings.

**REPAIR OR REPLACEMENT AS SET FORTH IN THIS LIMITED WARRANTY IS THE SOLE EXCLUSIVE REMEDY OF THE PURCHASER. AUTOMATIC SHALL NOT BE LIABLE FOR ANY INCIDENTAL OR CONSEQUENTIAL DAMAGES FOR BREACH OF ANY EXPRESS OR IMPLIED WARRANTY ON THIS PRODUCT. EXCEPT TO THE EXTENT PROHIBITED BY APPLICABLE LAW, ANY IMPLIED WARRANTY OF MERCHANTABILITY OR FITNESS FOR A PARTICULAR PURPOSE ON THIS PRODUCT IS LIMITED IN LENGTH TO THE DURATION OF THIS WARRANTY.**

Please visit <http://blueox.com/warranty/> to register your warranty

